



# Red Thread™ IIA Dualoy™ 3000/L Dualoy™ 3000/LCX

## Piping Systems General Installations Instructions

Time-Tested Fiberglass Primary,  
Secondary containment, and  
Coaxial piping for Underground Fuel  
Installations

---

**Fiber Glass Systems**

**NOV** Completion &  
Production Solutions

[nov.com/fgs](http://nov.com/fgs)

# Installation Statement

## Important - Read this First

1. This manual provides general recommendations for installation of our products. Always check the local regulations and owner's specifications for additional requirements.
2. Fiber Glass Systems, L.P. (FGS) does not warranty the installation of the goods nor shall it be responsible for the performance or workmanship of any person or entity engaged in the installation or installation supervision.
3. It is strongly recommended the installer to be properly trained. Fiber Glass systems offers several types of certification training classes and/or installation job startups.

Before beginning the actual assembly procedures, verify all individuals involved in the installation thoroughly understand the following suggestions and precautions.

Matching taper angles for the spigot and the bell make it possible to mechanically "lock up" a joint. Matching taper angles allow the joint to mechanically lock up, producing a thin line of adhesive called a glue line.

In all cases, the bonding surfaces must be clean before applying adhesive.

Joint strength of the bell and spigot joint is controlled by the adhesive thickness between the two matching tapered surfaces. The adhesive is relatively brittle in thick sections and fails easily if the bond line is too thick. Joint strength is controlled by the adhesive thickness-thin is good, thick is bad.



## Important - Read this First Cont'd

Joints that are not "locked up" during installation may pass an initial steady pressure test but can fail prematurely at a later date due to reduced bond strength caused by the thick adhesive. Therefore, it is essential that the installation crew be familiar with the joint concept and understand the importance of completely inserting and locking the spigot into the bell. Mechanical locking of the joint is absolutely essential to develop full strength of the joint.

Using mechanical force (such as hammering against a wooden block placed against a fitting or bell end of pipe) helps achieve "lock up". There are different installation procedures for both warm and cool weather installations. This concept is often overlooked when a crew installs piping and there are significant temperature variations throughout the day or week. Using mechanical force helps achieve joint lock up.

Cool weather conditions require special precautions when bonding pipe and fittings. The adhesive is very viscous (thick) when it is cool or when it is applied to cool pipe. This thick adhesive can be stiff enough to prevent complete joint "lock up". Follow the appropriate installation procedures for warm or cool weather.

All bonding surfaces must be factory fresh in appearance. When end caps have been lost, surfaces will weather and result in loss of bond strength. When surfaces are weathered, retaper spigots and sand bells to achieve a factory fresh appearance.

**Note:**

DO NOT USE T.A.B. COUPLINGS THAT ARE WEATHERED.



# Introduction

This manual is offered to assist in the proper fabrication and installation procedures when assembling NOV Fiber Glass Systems piping systems.

NOV Fiber Glass Systems piping systems are marketed as Red Thread IIA, Dualoy 3000/L and Dualoy 3000/LCX Primary, Secondary, and Coaxial Containment Pipe and Fittings.

Section 1: Details installation procedures for 2", 3", 4" and 6" (50, 80, 100, and 150 mm) diameter primary product piping.

Section 2: Explains installation procedures for 3", 4" and 6" (80, 100 and 150 mm) diameter secondary containment piping.

Section 3: Explains installation procedures for 2", 3", and 4" (50, 80 and 100 mm) coaxial pipe.

NOV Fiber Glass Systems' products must be installed and used in accordance with sound, proven practice and common sense.

The information supplied in the literature must be considered as an expression of guidelines based on field experience rather than a warranty for which NOV Fiber Glass Systems assumes responsibility. A limited warranty of the products is offered in the Terms and Conditions of Sale.

**CAUTION:** This pipe may carry hazardous material and/or operate at a hazardous pressure level; therefore, it is imperative the instructions in this manual are followed to avoid serious personal injury or property damage. In any event, improper installation can cause injury or damage. Installers should read and follow all cautions and warnings on adhesive kits, heat packs, etc. to avoid personal injury. Also, observe general safety practices with all saws, tools, etc. to avoid personal injury. Wear protective clothing when necessary.

Make sure work surfaces are clean and stable and that work areas are properly ventilated.



## Installation Training Seminars

Although any requirement for installation training is the responsibility of the regulatory authority, specifier, or end user, NOV Fiber Glass Systems recommends anyone directly involved in underground piping installations attend our installation training seminar.

In-depth training seminars cover both primary and secondary containment product installation procedures. The training seminar involves hands-on participation, and each attendee receives installation manuals used during the seminar. A written, open book test is given and a passing grade must be achieved. Each installer attending the seminar and passing the test receives documentary proof of attendance which expires after three years. Contact your local distributor or representative for information on these seminars.

To assist installers with proper installation of fiberglass piping systems, the FGS Installation Checklist for Underground Petroleum Pipe is available and is included in the Fuel Handling Catalog. For a copy of this checklist, contact your local distributor or representative.

# Table of Contents

Section 1— Installation Instructions for Red Thread IIA and Dualoy 3000/L Pipe  
Section 2 — Installation Instructions for Red Thread IIA and Dualoy 3000/L Pipe  
Secondary Containment Piping  
Section 3 — Installation Instructions for Dualoy 3000/LCX Coaxial Pipe

# Table of Content

<b>Read this First</b>	<b>i</b>
<b>Introduction</b>	<b>iii</b>
<b>Installation Training Seminars</b>	<b>iv</b>

## **Piping System Information** **4**

Pipe Products.....	4
Storage and Handling.....	5
Tools, Equipment and Supplies Required for Installation.....	8

## **Section 1**

### **Installation Instructions for Red Thread IIA and Dualoy 3000/L Pipe** **12**

Joining Systems.....	13
Layout and Preparation.....	14
Cutting & Tapering Pipe.....	15
Trenching & Backfilling.....	18
Joint Prep.....	22
Adhesives.....	23
Adhesive Mixing.....	23
Adhesive Working Life.....	24
Joint Assembly.....	29
Bell x Spigot Joints.....	29
T.A.B. Joints.....	30
Heat Assist Methods.....	31
Threaded Adapters and Reducer Bushings.....	35
Inspecting for Potential Causes of Joint Failure.....	36
Testing.....	36
Repair Procedures.....	40

## Section 2

### **Installation Instructions for Red Thread IIA and Dualoy 3000/L Secondary Containment Piping** **47**

General Concept.....	48
Layout and Preparation.....	50
Sump Connections.....	54
Joint Prep.....	58
Adhesives.....	59
Joint Assembly.....	60
Testing Recommendations.....	61
Locating Possible Leaks.....	63
Repair Procedures.....	64

## Section 3

### **Installation Instructions for Dualoy 3000/LCX Coaxial Pipe** **68**

Cutting.....	69
Tapering/Scarfig with Power & Manual Tools.....	71
Sump Penetration Fitting Installation.....	72
Adhesive for Containment Piping.....	75
Bonding Containment Piping.....	76
Terminating the Secondary Containment.....	77
Repair Procedures.....	78
Primary System Testing.....	80
Definition of Terms.....	83
Installation Check List.....	84



# Pipe Products

## Red Thread IIA Pipe

The pipe is thermosetting, fiberglass-reinforced epoxy that is light weight, provides long service life and fuel compatibility. UL/ULC Listed piping is available in 2-4" (50-100 mm) primary pipe sizes and 3-6" (80-150 mm) containment pipe sizes. T.A.B. (threaded and bonded bell x spigot) is the primary joining method for Red Thread IIA 2-4" (50-100 mm) primary pipe. Two-piece clamshell fittings are used on the containment pipe. Pipe comes in designated lengths up to 30 feet (9.1 m).



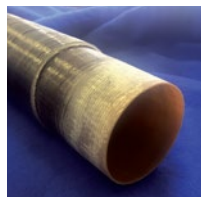
## Dualoy 3000/L Pipe

Epoxy pipe is similar to Red Thread IIA incorporating a resin-rich liner. UL/ULC primary pipe is available in 2-6" (50-150 mm) primary pipe sizes and 3-6" (80-150 mm) containment pipe sizes. Bonded bell x spigot is the joining method for the primary pipe. Two-piece clamshell fittings are used on the containment pipe. Pipe comes in designated lengths up to 40 feet (12.2 m).



## Dualoy 3000/LCX Pipe

Epoxy pipe where the containment on the pipe is coaxial and an integral part of the piping. The primary pipe incorporates the same liner as 3000/L. Primary bonding is done by bell x spigot joints and secondary containment utilizes the same clamshell fitting concepts as Red Thread IIA and Dualoy 3000/L pipe. Pipe is available in designated lengths up to 40 feet (12.2 m).



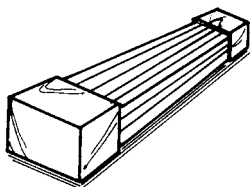
## Listings and Approvals

Red Thread IIA, Dualoy 3000/L and Dualoy 3000/LCX piping is Listed in the United States with Underwriters Laboratories for nonmetallic underground piping for motor fuels (MV), concentrated fuels (CF), high blend fuels (HB) and aviation (AvGas) and marine fuels (AM). The piping is also Listed with Underwriters Laboratories Canada (ULC) for the same fuel categories. The pipe has been third party tested and approved for Diesel Exhaust Fluid (DEF), Ethanol Blends, and Biodiesel Blends.

## Storage and Handling

### Packaging, Ordering, Shipping Information

Pipe comes in various sizes from 15' to 40' (4.5 to 12.2 m) depending on the product. The number of lengths per bundle varies with the pipe diameter. Two-inch (50 mm) Red Thread IIA pipe is supplied with a protective mesh covering. The protective mesh covering must remain in place on primary pipe that is not contained. The protective mesh covering may be removed when installed in containment pipe.



**Table 1.1**

Lengths of pipe - Red Thread IIA, Dualoy 3000/L and Dualoy 3000/LCX

Pipe Size		Random Length*		Quantity per Bundle		
in	mm	ft	m	RTIIA	Dualoy 3000/L*	Dualoy 3000/LCX*
2	50	15 - 40	5.6 - 12.2	8	8	3
3	80	15 - 40	5.6 - 12.2	6	6	3
4	100	15 - 40	5.6 - 12.2	4	1	varies
6	150	15 - 40	5.6 - 12.2	2	1	1

\* Random length for Dualoy 3000/L and 3000/LCX are 20 - 40 ft (6.1 - 12.2 m)

**Table 1.2**

Red Thread IIA, Dualloy 3000/L and 3000/LCX Primary Fittings per Box

Pipe Size		90° Elbows	45° Elbows	Tees	Sleeve Couplings	Adapters	Nipples	Bushings
in	mm							
2	50	20	20	12	25	25	25	20
3	80	12	15	6	12	12	12	24
4	100	6	6	4	5	5	N/A	9
6	150							

**Table 1.3**

Dualoy 3000/L Secondary Containment Clamshell Fittings per Shipping Box

Pipe Size		90° Elbows	45° Elbows	Tees	Couplings
in	mm				
2	50	5	5	5	5
3	80	5	5	5	5
4	100	5	5	5	5
6	150	N/A	N/A	N/A	N/A

**NOTE:** Fasteners are included with fittings**Table 1.4**

Red Thread IIA Secondary Containment Clamshell Fittings per Shipping Box

Pipe Size		90° Elbows	45° Elbows	Tees	Couplings
in	mm				
3	80	10	10	10	10
4	100	5	5	5	5
6	150	N/A	N/A	N/A	N/A

**NOTE:** Fasteners are included with fittings

Pipe is packaged in compact, easy-to-handle bundles complete with protective end caps. Caps should remain in place until installed to protect the pipe ends as well as prevent dirt or other material from entering the pipe.



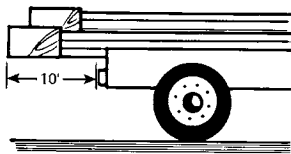
Fittings and adhesives should be stored in a cool dry area. If fittings are removed from the boxes, protect machined bells and spigots from exposure to direct sunlight.

## Storing

Bundles can be safely stored on level ground or on racks with 10 foot (3 meters) or less support spacing. Use supports with a minimum of four inch (100 mm) wide bearing area to prevent damage to the pipe. Do not store on rocks or other hard objects that could cause point-loading damage. When outdoor storage is required, check to assure the pipes' protective end caps are in place to protect the machined surfaces from weathering. Use black polyethylene or other ultraviolet ray blocking material to cover all factory-prepared bonding surfaces if end caps are missing or not available.

## Transportation

Use care in handling the pipe and fittings. When transporting from storage to the job site, do not allow pipe to extend more than 10 feet (3 meters) beyond the end of the truck or trailer bed;

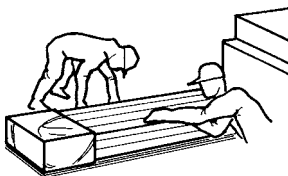


permanent damage can result from excessive bending stress. Protect pipe to prevent impact and point-loading damage. During transport, contact surfaces must be well padded to prevent damage to pipe wall. Strap the pipe down with nylon or hemp rope tie downs. This will help prevent abnormal movement of the pipe during transport.

Wood or padded supports are essential for truck or trailer beds that have sharp edges (such as metal plates on the back of a flat-bed trailer). When transporting the pipe on trucks with narrow overhead piping racks, padded supports must be used to prevent point loads.

## Loading and Unloading

When the pipe is not specially packaged, it should be loaded and unloaded by hand. When properly palletized or otherwise adequately protected, forklifts may be used. Do not throw or drop pipe and/or fittings from the truck to the ground.



## Tools, Equipment and Supplies Required for Installation

Following is a basic list of equipment that should be available before installation.

- Chain vise (bench mounted or portable) capable of securing the pipe size used. Use protective pads such as split sections of the same size fiberglass pipe or a sheet of 1/8" (3 mm) thick rubber to protect the pipe from clamp or chain damage.

- Felt tip marking pen.
- Pipe cutting equipment:
  1. Chop saw
  2. Fine-tooth (32 teeth per inch) hack saw
  3. Circular saw with abrasive cutting blade (carbide grit or masonry blade)
  4. Saber saw with carbide grit abrasive blade
- Wrap around (for marking pipe)
- T.A.B. wrench (for T.A.B. products only)
- Strap wrenches
- Rubber mallet and a 2" x 4" block of wood
- Adjustable pipe stands
- Power drive adapter (optional)
- Electric heating blankets or Chem Cure Pak® for cold weather installation.
- Clean rags
- 60-80 grit Emery® cloth (or sandpaper)
- Appropriate tapering tools.
- Drill with 3/8" Socket.

#### **Additional equipment for Dualoy 3000/LCX installations:**

- Dualoy 3000/LCX jacket cutter
- 1½" diameter by 1" wide coarse grit flapper sander
- Air Compressor – 5 CFM and pressure 60-90 psi
- 3/8" (9 mm) or 1/2" (12 mm) drill for flapper sander
- If a manual taper tool is used, a special notched blade must be ordered separately for use with Dualoy 3000/LCX.

## Equipment for Cold Weather Pipe Assembly:

- Heat sources for pre-warming:
  - Electric heating collars and/or Chem Cure Paks,
  - Portable electric heat lamp
  - Heat gun
- A means of maintaining adhesive kits at 65°-75°F (18°-24°C).
- Electric heating collars and/or Chem Cure Paks for curing joints
- A wooden enclosure to use with a heat gun to assist with curing joints. Contact NOV Fiber Glass Systems for recommendations

**Table 1.6**

Extension Cord Length

Wire Size	Suggested Length		Maximum Length	
	ft	m	ft	m
12	20	6	22	6.7
10	30	9	36	11
8	50	15	57	17

**Table 1.7**

Wattage Requirements for Electric Heating Blankets

Blanket Size		110V or 220V Heating Blanket
in	mm	Watts
2	50	90
3	80	155
4	100	200
6	150	285

## Table 1.8

Dualoy Heating Blankets

<b>Collar Size</b>		<b>110V or 220V Heating Collar</b>
<b>in</b>	<b>mm</b>	<b>Watts</b>
2 - 4	50 - 100	200
6 - 8	150 - 200	400



# Section 1

## Red Thread IIA and Dualoy 3000/L Pipe

- Joining Systems
- Layout and Preparation
- Cutting & Tapering Pipe
- Trenching & Backfilling
- Joint Prep
- Adhesives
- Adhesive Mixing
- Adhesive Working Life
- Bell x Spigot Joint
- T.A.B. Joints
- Heat Assist Methods
- Threaded Adapters and Reducer Bushings
- Potential Causes of Joint Failure
- Testing
- Repair Procedures

# Installation Instructions

## Primary Piping

- Proper installation is the key to achieving a highly reliable, adhesive bonded, matching taper, bell x spigot joint.
- Matching taper angles on spigot x bell ends make it possible to lock up a joint by wedging the spigot into the bell so that it takes significant force to separate them. Proper lock up is essential.
- A very thin line of adhesive (called the bond line or glue line) between the two matching tapered surfaces is necessary to achieve optimum joint strength.
- Proper installation results in joint strength equivalent to or stronger than the piping systems.
- To achieve the most reliable piping system, it is essential that the installation crew be familiar with the joining techniques in this manual.

## Joining Systems

The adhesive bonded, tapered bell x spigot joint is the primary joining method for 2”-6” (50-150 mm) pipe-to-fittings. When combined with the adhesive, the mechanical locking action promotes positive makeup of the joint and prevents back out during adhesive curing.

The T.A.B. joint is the primary joining method for pipe-to-couplings on Red Thread IIA. Red Thread IIA pipe is supplied with T.A.B. spigot x T.A.B. spigot ends. Fittings are manufactured to accept either a tapered spigot or T.A.B. spigot end of the pipe. T.A.B. couplings can also accept either a tapered spigot or T.A.B. spigot end of the pipe. Tapers can be made in the field with tools designed for this purpose. Bells cannot be field made. When a belled end is needed, a sleeve coupling is required.



**T.A.B. Joint and fitting**

## Layout and Preparation

While handling, storing, and transporting the pipe, it sometimes incurs rough treatment. Inspect all pipe surfaces for possible damage to the pipe wall and spigot ends. Damaged pipe must be cut out and replaced. Inspect fittings for damage. Impact damage on the pipe will appear as a light spot on the surface. Spigot damage will appear as a crack or ragged edge to the taper. Spigot damage can be remedied by cutting and re-tapering. If in doubt about damage, do not use the pipe.

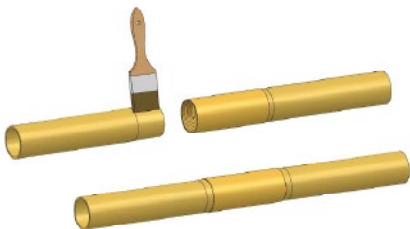
Exposing machined surfaces to direct sunlight prior to bonding can result in loss of joint bonding strength. Because the degree of weathering or surface degradation and subsequent effect on bond strength varies greatly, it is difficult to place a fixed time limit on the acceptable amount of exposure. In all instances where protective coverings are removed from machined surfaces and ultraviolet exposure exceeds one day, surfaces must be restored to factory-fresh condition.

### Layout

Advance planning of the piping layout can reduce the quantities of material required and will make servicing the system easier. Note: The scarfed containment pipe must be positioned over the primary pipe before bonding the primary pipe.

### Installation Crew Size and Organization

Each installation is different and requirements change depending on whether the installation is simple (long, straight runs of piping) or complex. Requirements are also affected by pipe size, installation temperature, and site locations.



Before beginning an installation, review the NOV Installation Checklist with the crew and fill out as the job progresses. A completed copy should be retained to document compliance with current State/Federal regulations. Installation checklists are available from your distributor or representative.

Following are general guidelines that apply to most piping installations:

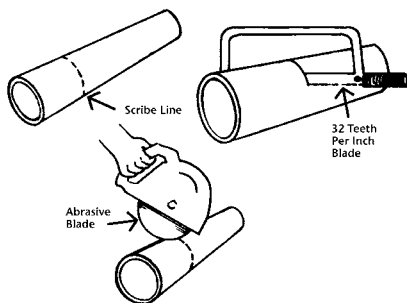
- The minimum recommended crew size is two. The crew size may be increased as the pipe diameter increase or when installing secondary containment piping.
- Organize the crew so the adhesive is spread on the bonding surfaces as quickly as possible after mixing the adhesive, particularly in extremely hot weather.
- Plan adhesive kit usage so that sufficient kits are available in the area where the bonding will take place.
- Plan ahead so a sufficient number of bonds are available to use one whole adhesive kit before the kit is mixed.

## Cutting and Tapering Pipe

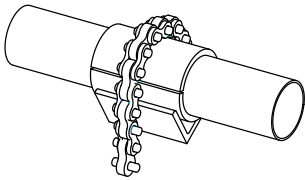
### Cutting

Cut pipe with one of the tools mentioned in equipment list.

When cutting, protect pipe from chain vise damage by placing rubber sections or sleeves (180° sections of pipe cut from the same size pipe being tapered) between the pipe and the chain vise.



Cutting the pipe



Pipe vice assembly

Cutting operations for fiberglass pipe can generate dust or cutting chips that are irritating to the skin, upper respiratory tract, and eyes. Because these materials are irritating, proper ventilation for the installation crew should be used to prevent exposure.

A nuisance dust breathing filter should be used when working in areas where dust will be present. Operators should wear heavy cotton clothing, including long-sleeve shirts that protect the skin from dust. Eye protection is required when operating tools.

## Tapering

Retract the protective mesh covering the 2" (50 mm) Red Thread IIA pipe approximately 12" (300 mm) from the end before tapering. It is important to avoid damaging the secondary pipe when tapering Dualoy 3000/LCX pipe. The following tools are available for tapering:

- Model 2100 Tool - Power tool designed to taper 2"-3" (50-80 mm) Red Thread IIA pipe and scarf 3"-4" (80-100 mm) Red Thread IIA pipe. Taper mandrels are available for Dualoy 3000/L pipe.
- Model 2102 Tool - Power tool designed to taper 2"-4" (50-100 mm) Red Thread IIA pipe and scarf 3" (80 mm) Red Thread IIA pipe.
- Model 2100-I and Model 2102-I - Available where 240 volt is required.
- Model 3000 Tool and 3000-I - Power tool designed to taper 2"-3" (50-80 mm) Dualoy 3000/LCX and scarf 2"-3" (50-80 mm) secondary wall.
- Model 3106 Tool - Power tool designed to taper 2"-6" (50-150mm) Dualoy 3000/L.

- Red Thread IIA Manual Tapering Tool – Tapers 2”-6” (50-150 mm) pipe, scarfs 3”-6” (80-150 mm) pipe.
- Dualoy Ratchet Pro Tapering Tool – Tapers 2”-6” (50-150 mm) Dualoy 3000/L and 3000/LCX pipe, with Carbide IV cutting blade. A special notched blade must be ordered separately in order to use this tool with Dualoy 3000/LCX.
- Other third-party tools, such as the Fairfield Air Shaver, are available for tapering.

Proper tapering tolerances are set at the factory. However, it is recommended the tool settings be checked prior to tapering pipe. To compensate for wear of the grinding drum, the mandrels can be field adjusted. Refer to the tool operating instructions for field adjustment procedures.



Model 2100 tool



Model 3000 tool

## Taper Lengths

- The tapering tools will produce a field-made taper that inserts into the same bell to  $\pm 1/8$ " (3 mm) tolerance when compared to a factory-made tapered spigot. The angle for properly made field tapers for 2"-4" (50-100 mm) diameter pipe should be  $1\frac{3}{4}$  degrees. All tapering tool settings should be checked at the beginning of each job.

**WARNING:** When tapering pipe with a 2000 or 3000 series power tool, DO NOT rotate pipe with your hand over the end of the pipe as this could result in serious injury. Place both hands firmly around the pipe and rotate counter-clockwise. Keep a firm grip on the pipe at all times and keep moving in a constant motion. If you loosen your grip on the pipe, the grinding drum could grab

the pipe and spin it backwards resulting in the pipe being locked up on the tool and possibly causing injury.

Several third party power tapering tools are available for use with NOV Fiber Glass Systems piping systems. It is the tool operator's responsibility to ensure that the tool being used is reproducing a field-made taper that is within the tolerances of a factory-made tapered spigot.

**Table 1.9**

Average Taper Insertion Length

Pipe Size		Average Taper Insertion Length	
in	mm	in	mm
2	50	1 - 1 7/8	25 - 48
3	80	1 1/4 - 2	32 - 50
4	100	1 1/4 - 2	32 - 50
6	150	2 1/8 - 3 1/4	54 - 83

## Trenching and Backfilling

Proper construction of trenches is important. They should be wide and deep enough to accommodate the piping and backfill material. See below for recommended minimum burial depths.

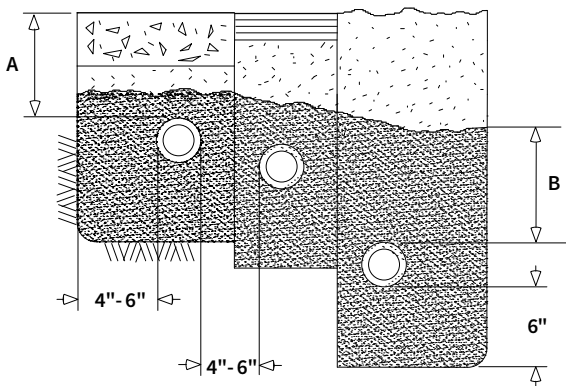
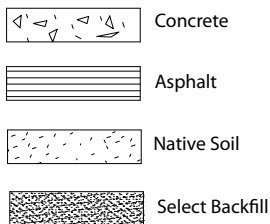
- Typically, piping should be sloped at least 1/8" (3 mm) per foot toward the tank. Support pipe properly to prevent low points.
- The piping should be separated by a distance of at least four to six inches (100-150 mm). For double-wall secondary containment piping installations, refer to Table 1.10 for recommended distance. Refer to Table 1.10 and Figure 1.1 for burial depth and backfill requirements.

**Table 1.10**

Trenching and Backfilling (to be used with Figure 1.1)

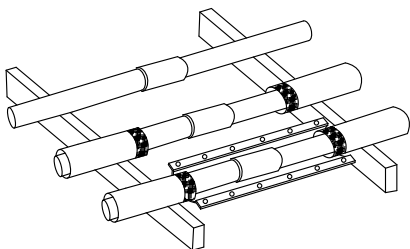
Pipe Size		Surface Condition	Min. Burial Depth		Min. Select Backfill	
			A		B	
in	mm		in	mm	in	mm
2	50	Unpaved	18	432	12	305
		Paved, min. 4" (100 mm) asphalt	12	305	8	203
		Paved, min. 4" (100 mm) concrete	9	229	5	127
		Paved, min. 6" (150 mm) concrete	9	229	3	76
3	80	Unpaved	20	508	14	256
		Paved, min. 4" (100 mm) asphalt	13	330	9	229
		Paved, min. 4" (100 mm) concrete	11	279	7	178
		Paved, min. 6" (150 mm) concrete	10	254	4	102
4	100	Unpaved	20	508	14	356
		Paved, min. 4" (100 mm) asphalt	14	356	10	254
		Paved, min. 4" (100 mm) concrete	11	279	7	178
		Paved, min. 6" (150 mm) concrete	10	254	4	102
6	150	Unpaved	36	914	14	356
		Paved, min. 4" (100 mm) asphalt	24	610	10	254
		Paved, min. 4" (100 mm) concrete	20	508	7	178
		Paved, min. 6" (150 mm) concrete	16	406	4	102





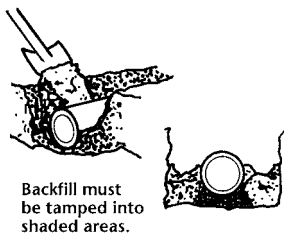
**Figure 1.1**  
**Recommended Trenching, Bedding and Backfill (see Table 1.10)**

During layout, bonding, and inspection, support pipe off of the ground (e.g., 2"x4") to keep joints clean and bedding out of pipe.



**Support off ground**

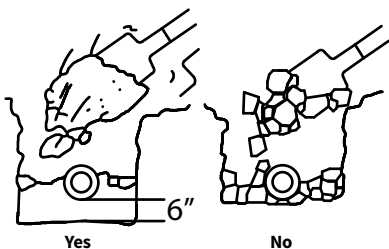
- Compact backfill carefully over and around the piping system. When using tamping equipment, take care to prevent vibration from driving small stones into the pipe wall. The amount of compaction and the type of soil determines the soil modulus. For example, pea gravel has a typical modulus of 1,000 psi with no compaction, while sand requires slight compaction (85% Proctor density) to achieve a modulus of 1,000 psi. Refer to ASTM D3839 or AWWA M45 for further details.



- Cover the pipe as soon as possible after successful testing to eliminate the chance of damage to the pipe, floating of the pipe due to flooding, or shifting of the line due to caving in of the trench walls. If damage is suspected, the lines should be retested.
- Take care to remove frozen lumps from all backfill materials before using. Frozen earth will eventually thaw, leaving the pipe with insufficient support and voids around the pipe.

In all cases, the pipe must be completely surrounded with select backfill (sand,  $\frac{1}{8}$ " to  $\frac{3}{8}$ " pea gravel, or  $\frac{1}{8}$ " to  $\frac{1}{2}$ " washed, crushed stone). There should not be any voids under or around the pipe. Six inches (150 mm) of the fill must be placed under the pipe as bedding material. Native backfill materials should never be used.

One of the most common causes of damage is paving stakes being driven through the product. Be careful that the stakes are not driven along the path of the piping.

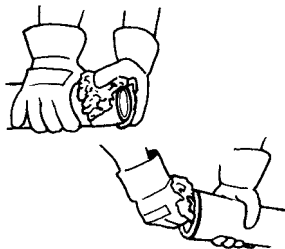


## Joint Prep

### Cleaning the Bonding Surfaces

Bonding surfaces must be cleaned before bonding. Do not touch the bonding surfaces or allow them to become contaminated after they are cleaned. Acceptable cleaning methods are as follows:

- Sand all bonding surfaces with 60-80 grit Emery cloth (sandpaper) until contamination is removed. The sanding operation must be light enough to prevent changing the taper angle.
- Cut off contaminated surface and replace with a new taper or sleeve coupling.
- Wire brushes may be used for cleaning T.A.B. surfaces; however, they must be clean and free of oil contamination.
- Clean solvent (fresh) may be used if preferred by the customer. Some typical cleaning solvents available are acetone, methylene chloride, and methyl ethyl ketone. After cleaning, be sure any residual solvent has evaporated before applying adhesive. Do not use solvents that leave an oily film on the bonding surfaces.



**WARNING:** Some de greasers and solvents are extremely flammable. Never use gasoline, turpentine, or diesel fuel to clean joints. All solvent should be evaporated. Read warning labels on containers before applying solvents.

### Reworking Weathered Surfaces (UV Degradation)

Pipe stored out-of-doors for extended periods of time may assume a chalky appearance. This change in appearance is superficial and does not affect the pipes performance. However, when machined or sandblasted surfaces of pipe and fittings are exposed to direct sunlight for a prolonged period of time, the result could be a loss of bond strength. All pre-prepared surfaces that have turned yellow or brown in color must be reworked.

For exposed T.A.B. ends, cut ½” (12.7 mm) minimum off of the end of the spigot and re-taper. Exposed fitting bells and pipe tapers should be lightly sanded with 60 to 80 grit Emery cloth (sandpaper) until the original factory-fresh appearance returns. T.A.B. couplings cannot be reworked. Damaged couplings must be replaced.

## Adhesives

The 8000 Series adhesives and PSX-20 adhesive are recommended for bonding primary fittings. PSX-34 is more viscous and can be used to bond primary fittings in warm weather conditions. For bonding secondary containment clamshell fittings, 8000 Series adhesive with the addition of a filler packet or PSX-34 may be used. See Table 1.11 for approximate number of bonds per kit. The working life of each kit is based on ambient temperature of 75°F (24°C).



Adhesive Series 8000



Adhesive Series PSX

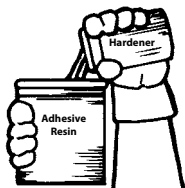
All adhesives are interchangeable in accordance with our UL 971 listing.

### Adhesive Mixing

All the adhesives are a two-component system that must be mixed prior to use. Detailed instructions for adhesives are provided with each kit. Read instructions thoroughly and follow the recommended procedures. Refer to Adhesive Working Life for both warm and cool weather conditions.

Thoroughly mix the adhesive. Complete information and safety precautions are packaged with each adhesive kit. Review all safety precautions thoroughly before mixing the adhesive.

- At 65°F (18°C) or below, pre-warm the adhesive kits to 80°-90°F (27°-32°C).
- Empty all of the contents of the hardener into the can of base adhesive resin.
- Mix all of the base adhesive resin with all of the hardener. NEVER SPLIT A KIT.
- Do not spill hardener during the mixing process. Cut through the adhesive with the edge of the mixing stick to assist in mixing the two components.
- Mix until the adhesive has a uniform color and a consistent flow off the mixing stick. Wipe down the sides, bottom, and under the rim of the can with the stick to assure a complete mixture.



## Adhesive Working Life

Working life or pot life is the time it takes for the adhesive to harden in the mixing can. This time is measured from the time the adhesive resin and hardener are first mixed. Working life is shorter at temperatures above 75°F (21°C) and becomes longer as the temperature drops below 75°F (21°C). Working life is affected by the quantity of mixed adhesive as well as by temperature. Use the following methods to optimize the working life of adhesives:

### Warm Weather:

- Occasionally stir the adhesive mixture during application.
- Use small ice chests or other containers with freezer packs to keep mixed adhesive cool.
- Spread mixed adhesive on a clean sheet of aluminum foil or cardboard.

### Cool Weather:

(When using open flames to heat be sure that there are no flammable fluids or gases present)

- Store adhesive kits inside.
- Pre-warm to between 80°-90°F (27°-32°C) before use.
- Keep adhesive stored in a temperature controlled room

- When temperature is below 65°F (18°C) pre-warm the adhesive with electric heating blankets, a hot air gun, portable torch or let the adhesive sit in the floor board of a truck with the heater running. Heat to between 80°F and 90°F (27°C and 32°C). Do not overheat as this could lead to a premature exothermic reaction.
- When the temp is 65°F (18°C) or below, heat cure with a NOV Fiber Glass Systems electric heating blanket or Chem Cure Pak.
- In the event of extreme or prolonged cold weather a portable heated cover made from tarps, a wood or PVC frame and propane heaters should be considered.

**CAUTION:** If adhesive becomes warm and starts to harden in the container, discard immediately. **DO NOT USE THIS ADHESIVE TO BOND A JOINT!**

When adhesive is allowed to harden in the metal container, the container may reach approximately 400°F (205°C). Do not handle hot containers without wearing heavy gloves. The exothermic reaction may generate fumes. Place the container outdoors in an open area until it cools. Avoid inhaling fumes.

### **Adhesive Disposal**

Once the adhesive and hardener have been mixed and reacted, nothing can be extracted and it is classified as non-hazardous material. Dispose in a normal manner as other solid waste. Excess adhesive and hardener can be mixed, allowed to react, and disposed as above. If extra cans of adhesive resin or hardener containers have accumulated without the other component to mix and react, contact your regional manager. These guidelines are based on federal regulations. State and local regulations and ordinances should be reviewed.

These adhesives are for NOV Fiber Glass Systems piping systems conveying gasoline, diesel, 100% ethanol or methanol, all alcohol-gasoline mixtures and bio-diesel fuels.

- When adhesive is properly mixed, it has a limited working life during which joints may be bonded. Use of the adhesive beyond the working life is prohibited.
- Number of bonds depends on ambient temperature.

**Table 1.11A**  
Adhesive Chart

Kit No.	Label Color	Mixed Qty	Number of Bonds per Kit Primary pipe fittings				Number of Bonds per Kit Secondary pipe fittings <sup>(4)</sup>				Working Life @ 75°F/Min.
			2"	3"	4" <sup>(1)</sup>	6" <sup>(2)</sup>	3"	4"	6"		
RT IIA											
8014	Green	6.5 oz.	21 <sup>(3)</sup>	15 <sup>(3)</sup>	8 <sup>(3)</sup>	5	1	1	N/R	15	
8024	Yellow	2.7 oz.	9	6	4	2	N/R	N/R	N/R	15	
8069	Orange	9.8 oz.	N/R	N/R	N/R	8	3	2	2	15	

Notes: N/A: Not Applicable | N/R: Not Recommended

<sup>(1)</sup> 4" tees require 1½ kits per fitting

<sup>(2)</sup> 6" tees require 2 kits per fittings

<sup>(3)</sup> Ambient temperature and adhesive working life should be considered when ordering adhesive.

<sup>(4)</sup> Coat only the bonded area of the secondary containment fitting.

**Table 1.11B**  
Adhesive Chart

Kit No.	Label Color	Mixed Qty	Number of Bonds per Kit Primary pipe fittings				Number of Bonds per Kit Secondary pipe fittings, LCX (3000L*)				Working Life @ 75°F/Min.
			2"	3"	4"	6"	2"	3"	4"	6"	
PSX•20	Red	3.0 oz.	7	5	3 ½	1 ½	N/R	N/R	N/R	N/R	25
PSX•20	Purple	5.0 oz.	12	8	6	2 ½	N/R	N/R	N/R	N/R	25
PSX•20	Yellow	8.0 oz.	N/R	14	9	4	N/R	N/R	N/R	N/R	25
PSX•34	Red	3.0 oz.	5	4	3	1	1 (NA)	1 (1½)	½ (1)	NA (N/R)	25
PSX•34	Purple	5.0 oz.	12	8	6	2	3 (NA)	1 (3)	½ (2)	NA (1)	25
PSX•34	Yellow	8.0 oz.	N/R	13	9	3	4 (NA)	2 (4½)	1 (3)	NA (1½)	25

**NOTES:** PSX adhesives contain granular filler to aid lock up. N/R: Not Recommended, NA: Not Available.

\* Number of Bonds per Kit: Secondary pipe fittings for 3000L products are in parenthesis.



**Table 1.12**

Minimum Cure Time in Hours

<b>Adhesive</b>	<b>55°F (13°C)</b>	<b>60°F (16°C)</b>	<b>70°F (21°C)</b>	<b>80°F (27°C)</b>	<b>90°F (32°C)</b>	<b>110°F (43°C)</b>
Series 8000	18	12	6	4	2	1
PSX•20	24	18	8	5	3	2
PSX•34	18	12	6	4	2	1

**NOTES:** Cure time is the time before the line can be tested. Times may vary depending on temperature, humidity, etc.

## Joint Assembly

### Bell x Spigot Joint

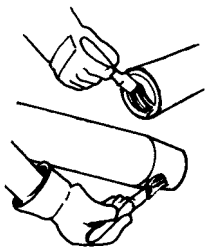
The spigot must be aligned and locked in the bell. A cocked or misaligned joint will not lock up and may lead to joint failure during testing or at a later date.

- When the temperature is below 65°F (18°C), pre-warm the bonding surfaces (after the joint has been cleaned). Caution: If a solvent is used, evaporation may be slow at extremely low temperatures. Use a heat gun and apply heat uniformly to the bell and spigot until warm (not hot) to the touch. Check temperature by touching outside of the bell and inside of the spigot to avoid contact with clean bonding surfaces. If hot to the touch, let cool before applying adhesive. If an electric heating blanket is used to pre-warm, place the joint together dry, then heat the O.D. of the bell to avoid contaminating the spigot.
- Brush or spread adhesive on both surfaces, applying a thin, uniform coating. To minimize contamination, apply adhesive to the bell first. Adhesive should always be worked into the prepared surface by applying pressure during application. Also lightly coat the cut end of the pipe wall with adhesive. This will wet out the prepared surface and maintain the required thin bond line. Be sure all surfaces in the bell and on the spigot and cut end of the pipe are uniformly covered. Excess adhesive will make the joint more difficult to lockup and can result in a flow restriction.

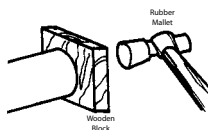
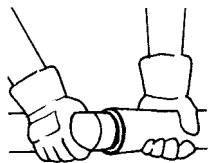


Connections into fittings are made using the normal bell and spigot method. A T.A.B. spigot can be bonded into a smooth bell (fitting), or a smooth spigot can be bonded into a T.A.B. bell.

- Align and lock the joint. For fittings, insert spigot into the bell until surfaces touch, then push and turn at the same time until a lock is achieved. Only a quarter turn to a half turn is usually needed. On 3" and 4" (80 and 100 mm) diameter fittings, pushing and turning to lock the joint is impractical.



If the adhesive or the pipe surfaces are cool, push and hold for a few seconds to allow time for the adhesive to start flowing out of the tapered joint. Apply the push-turn method after this period. If mechanical force is needed, use a rubber mallet against a wooden block to drive the joint together. A mechanical force such as a hammer and a wooden block or rubber mallet is required.

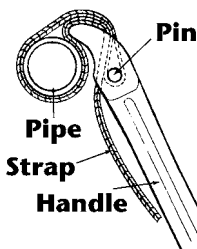


When the adhesive starts squeezing out of the joint, use stronger blows. Proper pipe alignment is important. Maintain back pressure against previously assembled joints to avoid shaking them loose. After the joint has started to make up, hit until no further engagement can be seen at the joint. When engagement stops, the joint is locked. Always check previous bonded joints to ensure they have not backed out. Do not hit the fitting directly with a metal hammer as damage may occur.

Check lock up by moving free end of pipe in an up-and-down or side-to-side motion. The movement must be sufficient to move the joint being checked. No movement between the joint components should be visible in the joint. If any movement exists, the joint is not locked up and the joint assembly procedure must be repeated.

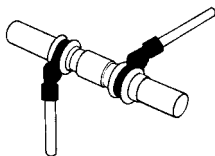
### **T.A.B. Joint**

T.A.B. joint installation procedures follow the normal bell and spigot operations of cleaning, adhesive mixing, etc. as described previously, but also involve rotating the joint components to engage the matching threads. The threads on the bonding surfaces are designed to improve the reliability of the joint lock-up, particularly under adverse conditions. Two T.A.B. wrenches or strap wrenches are recommended when joining 3" (80 mm) and larger T.A.B. pipe. Separate T.A.B. wrenches are available from the factory for each size pipe. The wrenches must be placed 6" to 12" (150 to 300 mm) from the joint to minimize ovaling and ensure proper make-up.



**CAUTION:** Improper use of strap wrenches can cause point-loading damage and/or bad joints that are locked up. To prevent damage to the pipe wall, wrap the strap wrench around the pipe as shown.

- Cover all machined areas on the spigot and at least one-half inch beyond the last thread in the bell with the adhesive.
- Screw the pipe together by hand, ensuring the joint is not cross threaded. Two inch (50 mm) diameter pipe can be hand tightened. To ensure complete joint make up for 3" and 4" (80 and 100 mm) diameter pipe, use T.A.B. wrenches.
- DO NOT OVER TIGHTEN.
- Check lock up by moving free end of pipe in an up-and-down or side-to-side motion. The movement must be sufficient to move the joint being checked. No movement of the joint components should be visible in the joint. If any movement exists, continue to tighten until no movement is visible.



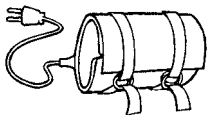
Connections into fittings are made using the normal bell and spigot methods.

## Heat Assist Methods

When working at temperatures below 65°F (18°C) or in situations where rapid cure is necessary, NOV Fiber Glass Systems has developed heat assist methods for curing adhesive bonded pipe or fitting joints.

### A. Electric Heating Blanket

- The most effective method of heat assist is electric heating blankets. Reusable 110/120 volt heating blankets are standard (220/240 volt heating blankets are available on special order and are shipped without the male plug).



- The curing operation should occur as soon as possible after the bonding operation. In cold weather, it is preferable to bond only the amount of pipe that can be cured during the same day. If a generator is used, assure the voltage and power supply is adequate for all of the units being used. When extension cords are used, make certain they can handle the total wattage of the blankets used.
- When temperatures fall below 50°F (10°C), fiberglass insulation should be added around heating blanket to achieve a proper cure.
- Pipe or sub-assemblies can be moved before the joints are cured if care is taken and the joint is not disturbed. Avoid bending or excessive movement.
- Refer to Heating Blanket Instruction for complete operating instructions.



Heating blanket temperatures should be checked to ensure they are operating within the recommended operating range: 280° - 340° F or 138° - 171° C. Check blanket temperatures by inserting a thermometer between the blanket and the joint.

Do not bend or fold heating blanket; this may break the heating elements and cause inadequate heat to cure the joint.

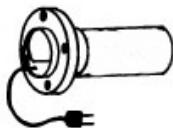
For Pipe and Fittings, use the same size heating blanket as the pipe size being installed, with the exception of flanges. Retract protective mesh covering on Red Thread IIA 2" (50 mm) pipe prior to use of heating blankets. Do not use a heating blanket that is designed for a larger size pipe. For recommendations on using a heating blanket when cutting into an existing system, contact NOV Fiber Glass Systems.

If you are using a non-insulated heating blanket and the temperature is below 70° F (21° C), an outer layer of insulation (minimum 2" thick with a R-value of 7) is recommended. If the temperature is below 50° F (10° C), the outer later of insulation is required.

**CAUTION:** The uninsulated area of the heating blanket is extremely hot when the blanket is on. DO NOT TOUCH with bare hands. Tighten the straps until the heating blanket is snug against the joint.



For 3" and 4" (80 and 100 mm) flange joints, use a heating blanket that is one pipe size smaller. Remove the straps from the heating blanket. Carefully turn the blanket inside out with the heated area facing the I.D. of the pipe. Place the heating blanket in the I.D. of the flange.



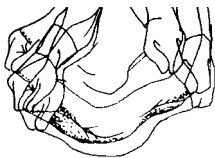
**Table 1.13**

Electric Blanket Cure Times

Piping System/ Adhesive Grade	Pipe Size		Cure Time/Minutes		
	in	mm	Pipe	Fitting	Flange
Series 8000	2 - 6	50 - 150	15	20	15
PSX•20 or 34	2 - 6	50 - 150	30 - 40		

Allow the joint to return to ambient temperature before applying stress to the joint.

**NOTE:** NOV Fiber Glass Systems' electric heating blankets are designed to fit around fittings and will overlap on pipe joints and couplings. Exceeding the recommended cure time on pipe joints where the heating blanket overlaps may shorten the life of the heating blanket and/or damage the pipe.



## **B. Chem Cure Pak**

Refer to Chem Cure Pak Literature included with each kit for complete instructions. Observe all safety precautions listed on the installation sheet.

The adhesive bead will cure faster than the adhesive in the joint. It is important that the joint not be pressurized until it has been subjected to the proper time-temperature cycle.

## **C. Cold Weather considerations**

A heat gun, collar or blanket may be used to obtain a faster cure time. Apply a layer of fiberglass insulation or a welding blanket around the heat collars or blankets when installation temperatures are below 50°F.

In addition, there are other tools and techniques that may be helpful during cold weather installation, such as the cure box shown below. Contact your local NOV Fiber Glass Systems representative for additional cold weather recommendations.

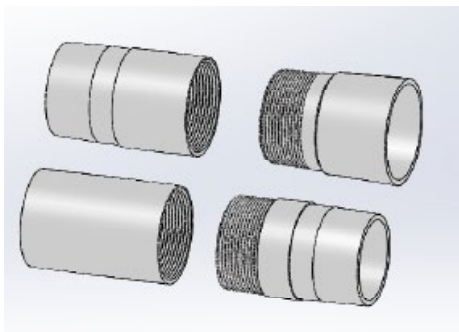


## Threaded Adapters and Reducer Bushings

Before making up threaded connections, inspect the threads. Do not use fittings with damaged threads. Inspect all steel threads and remove any burrs. Threads must be clean and dry before applying thread lubricant. When using threaded adapters, thread them into the other system before bonding onto pipe. Unless a union is used, it may be impossible to turn the adapter into the mating thread. For best results use a strap wrench and a solvent-free, soft-set, non-metallic thread lubricant. The thread lubricant must be chemically resistant (compatible) with the petroleum or alcohol product conveyed in the piping system.

### Threaded Adapters

- Do not use thread sealing tapes.
- Apply thread lubricant to all threaded surfaces.
- Series 8000 adhesive may be used in place of thread lube. Do not use PSX adhesives as a thread lube.
- Tighten to 1 to 1½ turns past hand tight.
- Do not use metallic wrenches that may cause damage to fittings.
- Do not over tighten. Tighten the adapters as if they were brass or other soft material.





## Inspecting for Potential Causes of Joint Failure

**Joint Backout:** When assembling a bell and spigot joint, a bead of adhesive is normally formed at the edge of the bell. If the joint is not locked up and backs out before the adhesive cures, the bead will no longer be next to the edge of the bell.

**Cocked Joint:** If a joint is cocked or misaligned, there will usually be a large gap between the bell and spigot on one side. The opposite side will usually have a smaller or no gap. Misalignment is easier to detect if one sights down the line and views the joint from a distance.

**Improperly Cured Joint:** If the adhesive bead is soft or flexible, the adhesive is not sufficiently cured. If the bead is cured, it is hard when checked with a knife. When the bead is not hard after exposure to the recommended temperature and time cycle, the adhesive was not mixed properly.

**Weather Damage:** If a joint has been exposed to sunlight for a period of time and the machined area has turned from white in color to yellow or brown and was bonded without a proper rework, the joint may be suspect and could leak or even separate. Inspect for color change on all machined areas before bonding.

Although not all inclusive, the conditions mentioned above are the most common indications of failure to achieve a properly assembled joint. All damaged or improperly assembled joints must be replaced. See Repair Procedures.

## System Testing

### Safety Precautions

NOV FIBER GLASS SYSTEMS SHALL NOT BE LIABLE UNDER ANY WARRANTY, CONTRACT, OR IN TORT, FOR ANY RESULTING INJURY TO PERSONNEL OR DAMAGE TO EQUIPMENT, PIPE, OR OTHER PERSONAL PROPERTY FOR FAILURE TO FOLLOW THE PROCEDURES AND COMPLY WITH THE PRECAUTIONS SET FORTH.

As in any system where pressure is employed, adequate safety precautions should be exercised.

NOV Fiber Glass Systems does not recommend testing any installation with air or gas because of the safety hazards created. The light weight, flexibility, and elasticity of fiberglass pipe create different conditions than are present with steel pipe. If a failure should occur while testing fiberglass pipe with air or gas, the system would be subject to considerable whipping and other shock-induced conditions due to the sudden release of stored energy. The violent release can cause severe personal injury or death to personnel in the area and can also cause damage to the pipe or other property.

If a line is tested with air or gas, NOV Fiber Glass Systems will not be responsible for any resulting injury to personnel or damage to property, including the pipe. Such testing is done entirely at the risk of those involved.

### **Testing General**

Installed pipe systems should be tested prior to use to assure soundness of all joints and connections. Locate pressure gauge in close proximity to the pressurizing equipment, not directly on the piping system. Below are general recommendations:

- Plan tests carefully and carry them out with all due precautions.
- Pressurizing equipment should be suited to the size of the system and the pressure required and should be operated by qualified and experienced personnel only.
- Pressure sources should be capable of approaching test pressure gradually.
- Use gauges with full-scale reading of no more than twice the test pressure. Do not use a 100-psi (0.69 MPa) gauge for a 10 psi (0.069 MPa) test. Use reliable gauges calibrated against a dead weight tester and zeroed for atmospheric pressure.
- Isolate tanks from the piping when pressure testing.
- Do not exceed 150% of system rating. Check the pressure rating of all the components of the system, not just the pipe, because hoses and flexible connectors are almost always rated lower than the pipe.
- Do not adjust fittings while system is under pressure. If threaded adapters or bushings leak, release the pressure before attempting to tighten.

## Hydrostatic Testing

The normal recommended procedure is to conduct a hydrostatic cyclic pressure test. The piping system should be subjected to 10 pressurization cycles at 1½ times the design operating pressure or the lowest rated component of the system. Pressure is then kept on the system for one to eight hours while the line is inspected for leaks. At a minimum, the line should be pressurized to 1½ times the design operating pressure (or lowest rated system component) for at least one hour.

## Air Testing

TESTING WITH AIR OR GAS IS EXTREMELY DANGEROUS. IF YOU CONTEMPLATE USING AIR OR GAS IN SPITE OF THE WARNING OR IF YOU WILL BE PRESSURIZING HIGHER THAN 1½ TIMES THE LOWEST RATED ELEMENT OF THE SYSTEM, REVIEW ALL SAFETY PRECAUTIONS BEFORE STARTING THE TEST.

If testing with air or gas is required or requested to be performed, the following testing procedures and precautions must be followed. EXERCISE DUE CARE IN INSTALLING AND TESTING THE PIPING SYSTEM.

- Visually inspect all bonded joints for proper insertion and adhesive cure prior to pressurizing the piping system. A gap between the adhesive bead and the fitting shoulder indicates the possibility that joint pull-out exists. Make any necessary repairs before pressurizing the piping system.
- Check the integrity of the joints by pressurizing the system to 25 psig (0.172 MPa) and holding the pressure for a minimum of one minute. Soap all joints to test for leaks.
- If there are no leaks, raise the line pressure in the system to a maximum of 50 psig (0.345 MPa). Again, hold the pressure for a least one minute and soap all joints to check for leaks.
- As serious personal injury or death can result, the pipe inspector should take precautions for his/her personal safety and protection against flying debris and also against the whipping action of the pipe that can result from the sudden release of stored energy. Adequate personal protective equipment should be used.

- Avoid direct contact with the piping system while it is pressurized during testing until the actual checking of the joints for leaks. Absolutely no one should be in the trench while the pressure in the pipe is being increased. Notify all site personnel before beginning the testing procedure.
- Do not straddle the pipe during testing or while checking the piping system for possible leaks. Stand to the side of the pipe.
- While the pipe is being checked for leaks, do not stand at the end of the piping system or where it changes directions.
- After the piping has passed the 50 psig (0.345 MPa) pressure test, reduce the product line pressure to a pressure of not more than 25 psig (0.172 MPa) and maintain this pressure until all paving has been completed. Leave pressure gauge on each line for inspection. The contractor should check the gauge daily to verify the pipe is holding pressure. Some fluctuation in pressure may occur due to temperature changes. Check for day-to-day changes when temperatures are near the same level.
- An alternative method to finding a primary leak after the secondary containment has been installed and bonded in place is to fill the secondary containment line with water, pump 10 psi max with air through the primary and look for air bubbles through the secondary containment pipe wall.

**CAUTION:** Failure to strictly follow these instructions can result in serious personal injury, death, and/or property damage.

If a leak is encountered during the test procedure, immediately release all pressure in the piping system and refer to repair section for proper repair procedures. Upon completing any necessary repairs to the piping system, follow the proper testing sequence and verify the system's integrity.

### **Vacuum or Detectable Gas Test Procedures**

Testing with vacuum and/or detectable gases (such as Helium) at low pressure has been successfully used with our piping systems. Although helium testing in a closed atmosphere and at measured levels is useful, testing in the field with helium has shown inconsistencies when attempting to identify leak location. These methods require specialized equipment and procedures that are beyond the scope of this manual.

## Repair Procedures

For damaged pipe, NOV Fiber Glass Systems recommends only the repair methods listed below. DO NOT attempt to repair damaged fittings. Always pressure test repair work before putting the line back into service to assure the soundness of the repaired section. Contact local representative for further information.

During repair, the pipeline should not be under pressure and the area to be repaired must be clean and dry throughout the procedure.

### For Red Thread IIA:

#### Pipe Patching

Follow these instructions to repair pipe wall damage where the damaged area is two inches (50 mm) or less in diameter:

- Cut the protective mesh covering and slide away from damaged area.
- Cut a length of good pipe long enough to adequately cover the damaged area and extend at least three inches (75 mm) and preferably four inches (100 mm) to each side of the damaged area.
- Slit the “patch” lengthwise twice and remove a section so that about three-fourths of the circumference remains.
- Thoroughly sand the inner surface of the patch and sand a corresponding area on the pipe around the damaged section. Use 60 to 80 grit Emery cloth or sandpaper, a file, or a disc sander to remove all gloss from the surfaces to be bonded.
- If solvent is used to clean all bonding surfaces, allow the solvent to evaporate then apply a thick coating of adhesive to both surfaces, snap the patch in place, and apply pressure with hose clamps or banding material until the adhesive hardens. Heat curing methods described above may be used if necessary. The clamps may be left on or removed after curing.



- Replace the protective mesh covering if the repair is made on 2” (50 mm) single-wall pipe.

### Using a Sleeve Coupling

- When damage is local (less than two inches (50 mm) long but more than two inches (50 mm) around the circumference of the pipe), check to see if there is enough slack in the pipe to cut out the damaged section. If so, cut out the damaged section, re-taper the cut ends, and bond a sleeve coupling between the tapered ends. The joints must be locked up and fully cured before pressure testing the repair.
- If the pipe is buried, excavate a working area large enough to allow for tapering tool rotation. Taper the cut ends of the pipeline and install the sleeve coupling.

### Using a Dualoy Repair Coupling

(See literature FH3520 for more details)

### Repairing Extensive Damage

When the damaged area in the pipe wall is larger than two inches (50 mm) in diameter.

- Cut out the damaged section, taper the cut ends, and install two sleeve couplings and a pipe nipple (and other components, if required). This procedure requires sufficient slack in the line to make the final joint by lifting the pipe (or moving the pipe to one side) to engage the bell and spigot joint. Therefore, it may be necessary to remove additional backfill from a buried line to allow the pipeline movement of several feet.
- Taper one end of a piece of pipe at least as long as the damaged section. This taper will be used as a gauge. Cut this nipple to the proper length in the following steps.
- To determine the insertion length of the tapered ends, move one of the couplings to the side and use the end of the repair nipple made in the previous step to determine the dry fit into each bell. (**NOTE:** The dry fit must be very tight, i.e. use additional force to drive the joint together tightly enough that it is difficult to separate.) The total length of the repair nipple is determined by adding these two measurements to the distance between the sleeve couplings and then adding the two make-up dimensions from Table 1.14.
- This added length is needed due to additional insertion that occurs because the adhesive acts as a lubricant.

**Table 1.14**

Make-up Dimensions (Wet)

Pipe Size		Make-up Dimensions	
in	mm	in	mm
2	50	1/8	3
3	80	3/16	5
4	100	3/16	5

**CAUTION:** This additional insertion will be greater if a tight, dry fit is not achieved when measuring.

- After the final nipple length is determined, cut the other end of the nipple and taper it, making sure the nipple is on the tapering tool in exactly the same position as the first taper that was used to measure the insertion length.
- If solvent is used to clean bonding surfaces, allow the cleaner to evaporate. Apply adhesive to all bonding surfaces and insert the nipple into the line by lifting the line or moving it to one side. Pushing the pipe back into the line will push the nipple into the bell. Make certain all tapers are tightly locked.
- Replace the protective mesh covering if the repair is made on 2" (50 mm) single-wall pipe.

### Leaking Joints

Any adhesive-bonded joint that leaks during pressure testing **MUST BE REMOVED AND REPLACED**. Follow the previous Extensive Damage procedures using two sleeve couplings and pipe nipple or fittings, as required.

After completing any necessary repairs to the piping system, follow the proper testing sequence to verify the system's integrity.

### For Dualoy 3000/L:

Repair couplings are produced in 2-6 inch (50-150 mm) sizes. These couplings are Listed by Underwriters Laboratories, Inc. for use in buried fuel systems and can be installed without in-trench tapering.

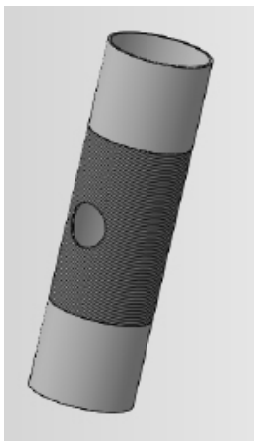
When repairing lines which have already been in service and which may contain flammable fumes, do not use electric drills or other tools which may constitute a spark hazard near the pipe. Use only air-driven or manual tools for repair.

## Minor Damage

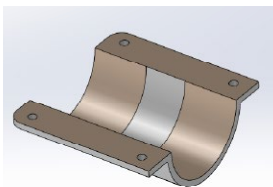
Minor damage (delaminated areas under 1 inch (25 mm) in diameter) is typically caused by impact and appears in the form of light discolorations or small circumferential cracks. Minor repairs can be made using half or full repair couplings.

Remove the affected area with a hole saw.

- Clean all burrs from edge of hole



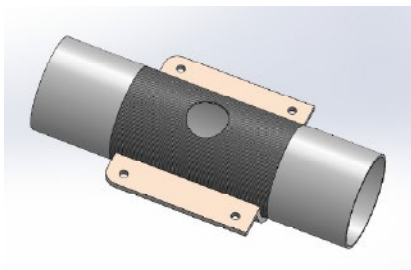
**Figure 1.2**  
Damaged area removed with hole saw



Sand bonding surfaces



- Using a flapper sander or 60 to 80 grit Emery cloth, abrade the pipe where it will contact the repair coupling halves and the entire inner surface of the coupling.
- Apply PSX•20 or PSX•34 adhesive to the cut edge of the hole and to the sanded areas.
- Position the coupling halves so that the hole is centered and 90° away from the flanges.
- After bolting the halves together, an adhesive bead should be visible around the edges of the coupling halves.
- Allow the adhesive to cure before pressurizing the system.



**Figure 1.3**  
Apply adhesive to cut edge of hole and sanded areas

### **Moderate Damage (under 3 inches (75 mm) in length)**

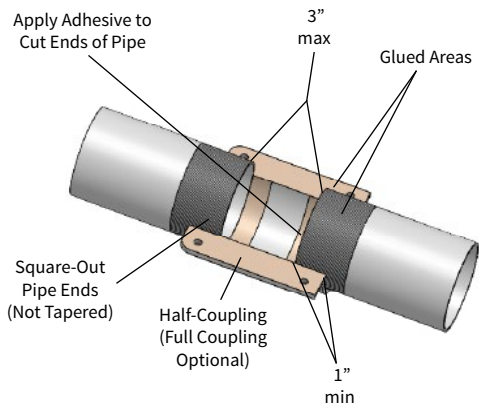
If cracks and delaminated areas are too extensive to be encompassed by a hole saw, removal of a short section of pipe is necessary. For damage three inches or less in length, a repair coupling can be used to make the repair.

- If using a half-coupling, align it precisely to maintain spacing requirements. The use of a full coupling is recommended.

The ends of the pipe must be within 3 inches (80 mm) of each other for this repair procedure to maintain the UL listing. Similarly, pipe insertion of at least 1 inch (25 mm) in the Repair Couplings must be maintained.

- Center the coupling around the gap in the pipe.
- Abrade all bonding surfaces before applying adhesive.
- Coat the cut ends of the pipe and bonding surfaces with adhesive, then bolt the coupling halves together.

**Figure 1.4**  
Repair Coupling repair - 3" (75mm) or less

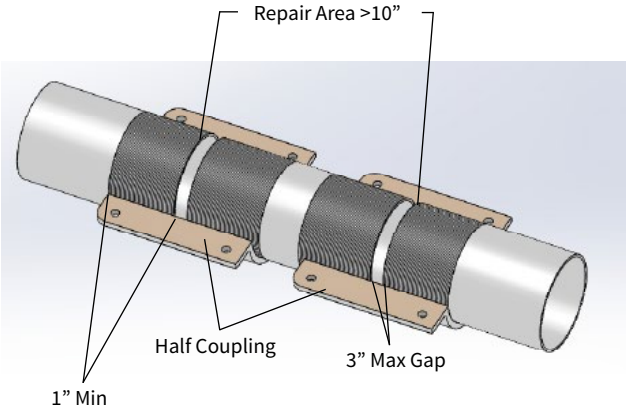
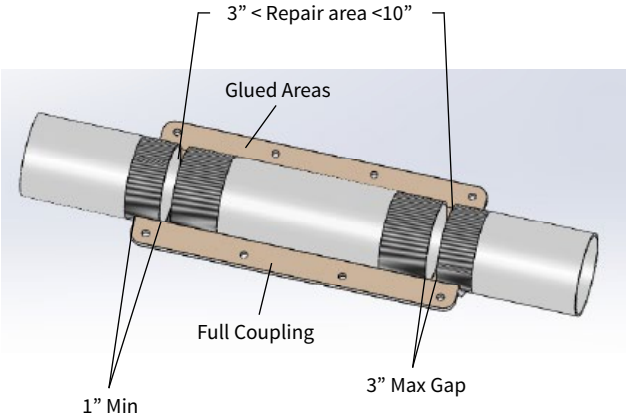


### Major Damage (over 3 inches (75 mm) in length)

Damage in which more than three inches of pipe must be removed is considered major. Major damage is typically caused by excavation equipment or large objects striking the pipe. Repair major damage with a replacement nipple (and any necessary fittings) and one or more repair couplings.

- For damage less than 12 inches (300 mm) in length, a single full-size, 14 inches (350 mm) long coupling will provide the required 1 inch (25 mm) pipe insertion at each end.
- To make repairs greater than 12 inches (300 mm) in length, use two full-size or half-couplings to join the replacement nipple with the existing line as shown.
- Follow the guidelines given for minor damage, abrade all bonding surfaces, coat all cut pipe ends with adhesive and observe spacing and insertion depth requirements.

**Figure 1.5**  
Repair Coupling repair - over 3" (75mm) in length



# Section 2

## Secondary Containment Piping for Red Thread IIA and Dualoy 3000/L

- General Concept
- Layout and Preparation
- Sump Connections
- Joint Prep
- Adhesives
- Joint Assembly
- Testing Recommendations
- Locating Possible Leaks
- Repair Procedures

# Secondary Containment Piping

The secondary containment piping system for Red Thread IIA and Dualoy 3000/L product piping consists of the next larger size pipe and special two-piece fittings. **NOTE:** All containment piping MUST be fitted in place on the primary system prior to the primary system being bonded. All scarfing of the pipe ends must be done prior to placing the containment pipe over the primary.

Many of the procedures used for installing primary product pipe and fittings are also used for installing secondary containment pipe and fittings. Refer to tapering/scarfing tool operating instructions.

Following are useful sections previously outlined:

Storage and Handling, Layout and Preparation, Tool and Equipment List

Tools are recommended to achieve a maximum of 8 foot-pounds of torque:

- Variable speed impact wrench with 3/8" (9 mm) socket
- Variable speed drill motor with 3/8" (9 mm) socket
- One 3/8" (9 mm) wrench or nut driver

## Secondary Containment Pipe

NOV Fiber Glass Systems' secondary containment piping sizes are shown in Table 2.1:

**Table 2.1**

Size-over-size systems

Containment Pipe Size		Primary Pipe Size	
in	mm	in	mm
3	80	2	50
4	100	3	80
6	150	4	100

## Secondary Containment Fittings

Available secondary containment fittings are tees, 90° elbows, 45° elbows, couplings, crossover nipples, concentric reducers, termination fittings (with or without ¾" NPT threaded outlet), and sump entry termination fittings. Inserts are required on 3" (80 mm) and 4" (100 mm) 90° elbows and tees for Red Thread IIA Closed Systems (capable of Interstitial Monitoring). Inserts are not required for Open Systems or Dualoy 3000/L Closed Systems."

## Adhesive for Secondary Containment Piping

When joining secondary containment, fiberglass filler must be added to the 8000 Series adhesive to ensure optimum performance of this type of bonded joint. PSX adhesives do not require fillers.

Filler is available from NOV Fiber Glass Systems. Due to the quantity of adhesive required for joining secondary containment fittings, it is recommended that only 8069 kits be used for Red Thread IIA systems and 8 oz. PSX•34 for Dualoy 3000/L systems. If 8014 kits are used, please note that extra kits (50% more than 8069) must be used for each secondary containment fitting.

## Layout and Preparation

Before installing the secondary containment piping system, review and verify the recommendations for proper installation set forth previously in the Layout and Preparation section (Refer to Installation Crew Size and Organization).

### Piping Layout, Pipe Trenches and Burial

Most of the standard procedures for installing a secondary containment piping system can be handled by the same size crew that would install a single-wall product piping system. It is essential that each phase of an installation be evaluated and the proper number of workers be assigned to assure an efficient installation.

### Scarfig Pipe

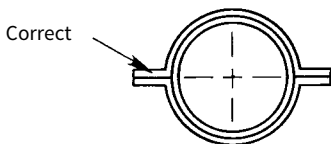
It is recommended that scarfig be done prior to placing the containment pipe over the primary pipe. Do not use a tapered pipe spigot with secondary containment fittings. If scarfig is not done prior to placing the containment pipe over the primary, and the primary system is bonded, abrading the surface must be done manually using 60 to 80 grit Emery cloth or sandpaper.

The ends of the containment pipe that are to be joined to secondary containment fittings must be thoroughly scarfiged for a minimum length of 3 inches (80 mm) for Red Thread IIA and 1½" (40 mm) for Dualoy 3000/L pipe. Refer to Installation Instructions for scarfig tool.

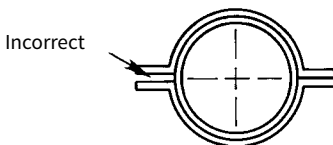
To scarf 3" and 4" Red Thread IIA pipe, the 2100 Power Tool is recommended. The 2100 is designed to taper 2" and 3" pipe and scarf 3" and 4" pipe. The 2102 Power Tool will only scarf 3" pipe.

If power tools are not available, the ends may be scarfiged using the manual tapering tool in conjunction with a secondary containment scarfiging adapter kit. This kit consists of a special scarfiging blade (approximately 4"/100 mm long), scarfiging blade holder, 1/8" Allen® wrench, and 3" and 4" (80 and 100 mm) scarfiging gauges, that are required to set the tool tolerances. The scarfiging adapter kit is easily adapted to the 2"-6" (50-150 mm) manual tapering tool kit.

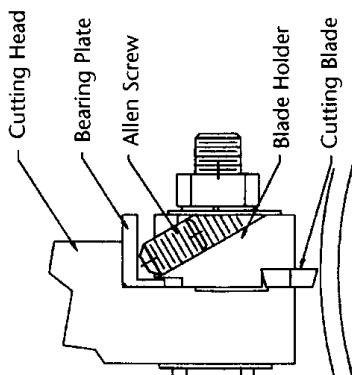
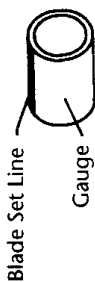
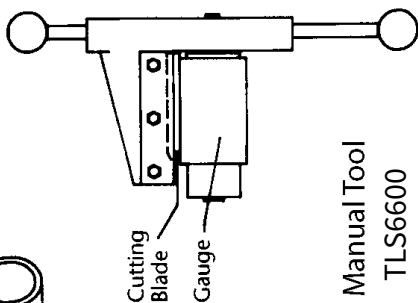
**Figure 2.1**  
Scarifying Pipe



Scarf O.D. of pipe so that the clam shell fitting halves fit together when assembled by hand



If there is a gap between the clam shell fitting halves when assembled by hand, pipe must be scarfed more.





## Piping Layout

Pre-installation of the secondary containment pipe is best accomplished at the same time the product pipe is dry fitted together. Typically, the length of Red Thread IIA containment pipe should be 4" (100 mm) shorter than the primary pipe. For Dualoy 3000/L, the pipe should be 2" (50 mm) shorter than the primary pipe.

**WARNING:** Fit all Red Thread IIA secondary containment connections to assure the insertion is approximately 3" (75 mm). Fit all Dualoy secondary containment connections to assure the insertion is approximately 1" (25 mm) to 1½" (40 mm). Be sure the containment pipe is not inserted too far into the containment fitting. None of the glossy O.D. of the pipe should be seated in the containment fitting.

## Containment Fittings

All containment fittings consist of two halves with flanges. The bottom half has threaded inserts for ease of assembly. These fittings are assembled with adhesive and ¼-20 washer head bolts that are furnished with the fittings. The required bolts are supplied in small plastic bags. If extra bolts are required, they can be purchased from your distributor or standard ¼-20 x 1" long hex head bolts can be used. If standard bolts are used, place a flat washer on the bolt before torquing.

The bonding surfaces of the containment fittings are pre-sanded when manufactured. These surfaces should be freshened with Emery cloth prior to bonding. Two-piece secondary containment fittings must be joined using a greater amount of adhesive (thicker adhesive layer) than is necessary for joining tapered bell and spigot joints of product piping.

## Red Thread IIA Containment Crossover Detail

When installing a secondary containment system, some preparation is necessary if the closest possible separation of lines is required. To minimize the overall change in elevation when installing a containment crossover, it is necessary to shorten one leg of the 45° containment elbow and the side outlet run of the containment tee. These parts can be purchased or can be field fabricated as noted below.

Refer to Table 2.2 for the maximum length that can be removed and for the minimum nipple length of both product piping and secondary containment piping.

**NOTE:** Use self-tapping screws or match drill two holes (5/16") at a distance of 3/4" (19 mm) from the cut end of the 45° elbow containment fitting and the tee containment fitting. This is to assure a compressive force is applied near the end of the containment fitting adhesive bond line.

**Table 2.2**

Containment Crossover Dimensions, Red Thread IIA

Fittings	Containment Pipe Size		
	3" Max. in	4" Max. in	6" Max. in
Remove from 45° elbow	1.25	2	1.25
Remove from branch of tee	1.5	1.63	1
Product nipple size <sup>(1)</sup>	2 x 8	3 x 8	4 x 10
Containment nipple size	3 x 6	4 x 6	6 x 8

<sup>(1)</sup> Actual length of the product nipple will vary slightly because of different insertion lengths due to variations of tapers.

To prevent interference of the pipelines, do not locate two containment fittings closer than shown in Table 2.3 and in Figure 2.2.

**Table 2.3**

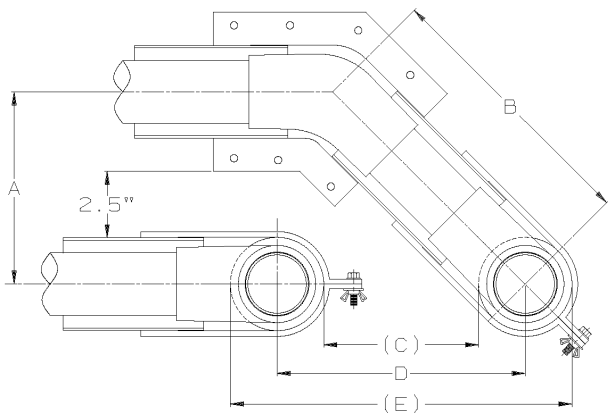
Pipe Separation Distances

Containment Pipe Size		A		B		C		D		E	
in	mm	in	mm	in	mm	in	mm	in	mm	in	mm
3	80	7.5	191	10.6	269	6.5	165	10.0	254	14.5	368
4	100	8.5	216	12.0	305	7.5	191	12.0	305	16.5	419
6	150	10.65	271	15.0	381	8.0	203	14.75	375	22.0	559

### Dualoy 3000/L Containment Crossover Detail

The procedure for making crossovers are identical to those used for making Red Thread IIA with the exception that the legs of the containment fittings crossovers do not need to be shortened to accommodate putting the primary fittings in close proximity.

**Figure 2.2**  
Containment Pipe Separation

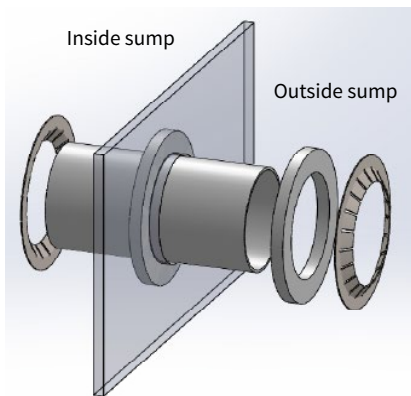


**NOTE:** The 2.5" (64 mm) critical dimension must be inspected in the field.

## Sump Connections

### Single Wall Sump Entry/Termination Fitting

(Refer to installation information included with each fitting)



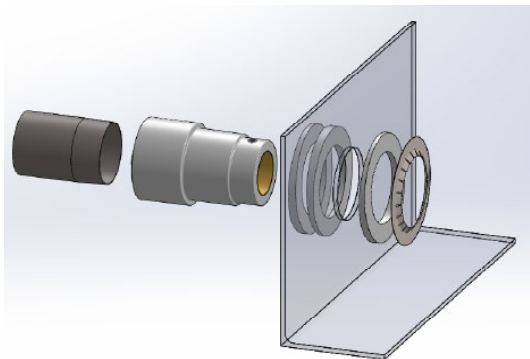
**Figure 2.3**  
Single wall sump entry/  
Termination fitting

## Double Wall Sump Entry Fitting

(Refer to installation information included with each fitting)

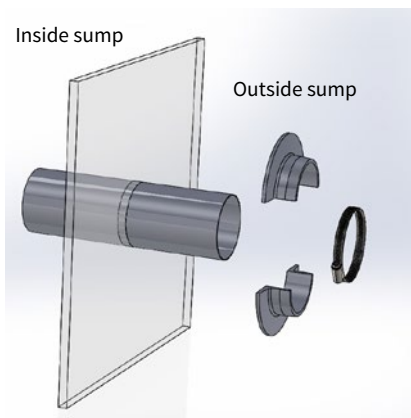
**Figure 2.4**

Bonded Sump Entry Fitting/Termination Style - Fiberglass Alignment Rings (Refer to installation information included with each fitting.)

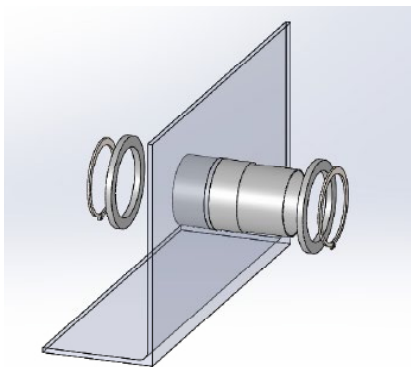


**Figure 2.5**

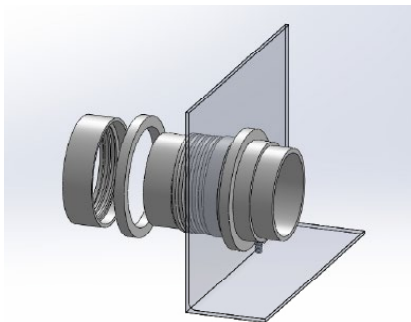
Split Sump Entry Fitting for Pass-Thru Installations (refer to installation information included with each fitting)



**Figure 2.6**  
Pass-Through Style and Termination Style



Pass-Through Style

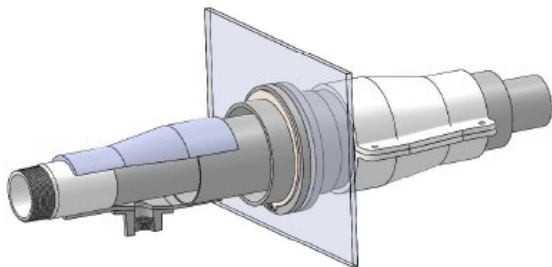


Termination Style

### **Red Thread IIA Alternate Termination**

See Figure 2.7. Termination of the secondary containment piping system at the storage tank is accomplished using a termination fitting with  $\frac{3}{4}$ " (19 mm) female NPT threaded outlet. The  $\frac{3}{4}$ " (19 mm) threaded outlet allows easy access for pressure testing of the secondary containment piping system and may also be used as an access for a leak detection probe. The large end of this termination fitting is bonded to the scarfed end of the containment pipe; the small end is bonded to the sanded surface of the adapter.

**Figure 2.7**  
Red Thread IIA Alternate Termination



**Table 2.4**

Termination Fitting Part Numbers

Part Number	Termination Fitting Size		Large End Fits Pipe		Small End Fits (Male threaded adapter or coupling) <sup>(1)</sup>	
	in	mm	in	mm	in	mm
012030-236-3 w/tap 012030-235-3 w/o tap	3x2	80x50	3	80	2	50
012040-236-3 w/tap 012040-235-3 w/o tap	4x3	100x80	4	100	3	80
012060-234-7 w/tap 012060-235-7 w/o tap	6x4	150x100	6	150	4	100

<sup>(1)</sup> A scarfed O.D. BxM adapter or coupling is available for use with the termination fittings.

**NOTE:** For Dualoy pipe, two-piece concentric reducers are available for terminating the containment in sizes 6" x 4" (150 x 100 mm), 4" x 3" (100 x 80 mm), 3" x 2" (80 x 50 mm) and 3" x 1½" (80 x 38 mm) with or without NPT threaded outlet and pre-assembled galvanized pipe nipple and coupling. The large end of the concentric reducer is bonded to the scarfed end of the containment pipe, the small end is bonded to the sanded surface of the primary pipe.

## Joint Prep

### Installation Preparation

Before bonding the two-piece containment fittings, the installation procedures should be reviewed with the installation crew members.

### Cleaning the Bonding Surfaces

It is required that all bonding surfaces are cleaned before bonding. **DO NOT TOUCH THE BONDING SURFACES OR ALLOW THEM TO BECOME CONTAMINATED AFTER CLEANING.**

Acceptable cleaning methods are as follows:

- Sand all bonding surfaces until restored to factory-fresh condition, removing any contamination.
- Dirt contamination can be removed by water washing. Be sure the surfaces are dry and re-sanded before bonding.
- Sand all surfaces that have been exposed to sunlight and have turned yellow or brown in color.
- Use of a solvent as a cleaning method is optional. Some cleaning solvents are acetone, alcohol, methylene chloride, and methyl ethyl ketone. After cleaning, be sure any residual solvent has evaporated before applying adhesive. **DO NOT USE SOLVENTS THAT LEAVE AN OIL FILM ON THE BONDING SURFACES.**

**WARNING:** Some degreasers and solvents are extremely flammable. Be sure to read warning labels on containers. Never use gasoline, turpentine or diesel fuel to clean joints

## Adhesives

See Section 1 for adhesives for mixing, usage and labeling information.

### Filler For 8000 Series Adhesive

For 8000 Series Adhesive, filler is required to thicken the adhesive for secondary containment joints. It is packaged in pre-measured quantities for use with 8014 and 8069 adhesive kits. One bag of filler is used for each adhesive kit. Before adding the filler to the mixed adhesive, be sure both the adhesive base and hardener are thoroughly mixed together. All of the filler in the bag should be used. The thickened adhesive may be applied with either the brush or the mixing stick provided in the kit.

The number of bonds per kits containment fittings is available in Table 1.11B.

The number of bonds per kit is based on applying a 1/16" (1.6 mm) minimum thickness of adhesive to both halves of the fitting and to the pipe ends.

Complete information and safety precautions are packaged with each adhesive kit. Review all safety precautions thoroughly before mixing the adhesive.

Adhesive Disposal - See Section 1 for instructions.



## Joint Assembly for Red Thread IIA and Dualoy 3000/L Secondary Containment Piping

Prior to bonding, make sure the pipe fits snugly into the ends of the two-piece fittings and there are no gaps between pipe ends and assembled fitting “sockets”. A properly bonded joint should have adhesive visible from all bonded surfaces.

After cleaning the inside surfaces (I.D.) of both halves of the two-piece fitting, apply a thick coating (1/16” - 1.6 mm minimum) of Series 8000 Adhesive with Filler or PSX-34 Adhesive to the surfaces to be bonded of both halves of the fitting, including the flanges (flat bonding surfaces). For Red Thread IIA, coat only the area to be bonded. Next apply a thick coating (1/16” - 1.6 mm minimum)

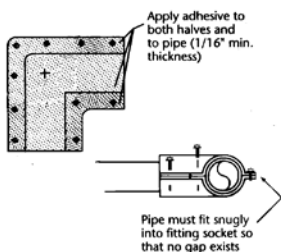


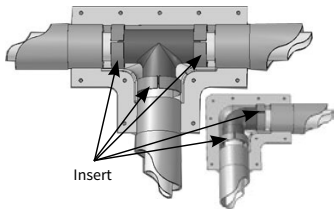
Figure 2.8

of adhesive to the scarfed or sanded surfaces of the pipe ends.

Assemble the containment fitting by placing the half with the pre-installed threaded female inserts on the bottom. Insert the pipe in the fitting. Do not insert pipe past the scarfed area. Apply top half of the containment fitting. Use the bolts supplied with the clamshell fitting to assemble the fittings on the pipe. Use of an air or electric wrench with a magnetic socket will greatly facilitate assembly. When starting the bolts, allow the bolt to start with minimal pressure on the tool. Excessive pressure may push the insert from the fitting. Tighten the bolts alternately and with equal force. Do not exceed 8 ft•lbs of torque. For elbow and tee containment fittings, it is recommended that the inner side of the fitting be assembled first (inner radius of elbow or sides of the branch of a tee).

On occasion the recess nuts on the secondary containment fittings will back out and fall off. IF this happens use a pair of Channel® locks or plyers to hold the nut while tightening. if the nut is lost standard nuts and bolt or a C clamp may be used to hold the fitting together while the adhesive cures.

For Red Thread IIA pipe, inserts must be used on 3" (80 mm) and 4" (100 mm) 90° elbows and tees for closed systems capable of being interstitial monitored. Inserts are not required for Open (Gravity Flow) Systems. Prior to bonding the insert, spread the insert splice 3 or 4 times to relax the insert. The insert may be placed on the containment pipe or primary fitting for easy access prior to bonding of the containment fitting.



**Figure 2.9**  
Closed Interstitial Monitored System Inserts

Locate the inserts next to the inside radius of the containment fitting, as shown on Figure 2.9. The split in the insert must be facing up (90° to the flanges). Do not allow insert to overlap itself.

### Joint Cure

An industrial heat gun and heavy duty aluminum foil may be used to create a mini oven around the secondary containment fitting. Wrap foil around the fitting and cinch the ends down. Cut a 10" to 12" (250 to 300 mm) section of 2" (50 mm) or 3" (80 mm) pipe and place inside the foil. Place heat gun in the end of the pipe. Do not place heat gun any closer than 12" from the fitting. Cure time is approximately 15 minutes. For a proper cure, maintain the temperature between 250°F (121°C) and 400°F (204°C).

## Testing Recommendations

### For Secondary Containment Piping

Secondary containment piping, 3"-6" (80 mm - 150 mm) diameter sizes, can be pressure tested by installing an in-line tee with a pressure gauge and a nipple in the 3/4" threaded outlet of a termination fitting. If the test piping is to be installed temporarily, use care not to over tighten when installing the steel pipe threads. Fiberglass threads may be damaged when removing the steel threads if over tightened. Use soft-set, non-metallic thread dope only.

NOV Fiber Glass Systems recommends testing 3", 4", and 6" (80, 100 and 150 mm) secondary containment piping systems with air at pressures not to exceed 10 psig (0.069 MPa). The most convenient place to introduce air for the containment piping pressure test is at the threaded outlet located on the termination fitting near the underground storage tank. The system should stay pressurized until the installation is completed to monitor for possible damage to the containment piping system during additional construction.

The low pressure and low volume of the secondary containment piping system makes air testing a relatively safe procedure if normal safety precautions are followed. Refer to air safety precautions.

### **For "In Service" Secondary Containment**

Secondary Containment piping systems can be tested after the line has been installed and in operation for a period of time. All systems must be shut off before testing. It is recommended that where possible, the air input valve be in a different location than the pressure gauge. Please read and understand all safety instructions and considerations in the Installation Manual before testing.

### **Closed Systems**

Test 3" (80 mm) and 4" (100 mm) secondary containment closed systems with air at pressures not to exceed 10 psig (0.069 MPa). Pressure should be left on the system for a minimum of one hour. The test pressure should not exceed the pressure rating of any component in the piping system.

### **Open Systems (Gravity Drain)**

Test 3"-6" (80-100 mm) secondary containment open systems with air to the equivalent static head test pressure listed in Table 2.6. The pressure should be left on the system for a minimum of one hour, or long enough to soap the joints. The system must be temporarily sealed during testing. Do not exceed the pressure rating of any component in the piping system.

## Table 2.6

Test Pressure for Open Systems

Feet of Head*	Test Pressure in psi
2	1.0
4	2.0
6	2.5
8	3.0
10	4.0
12	5.0

\* Highest point in system minus the lowest point in system. These test procedures are designed specifically for the NOV Fiber Glass Systems' piping systems. The company is not responsible for any damage to other products in the systems such as rubber boots, hoses, etc. Please contact the manufacturer of other products for their recommended maximum test pressure and time.

## Locating Possible Leaks

Leaks in NOV Fiber Glass Systems fuel handling pipes are rare and are usually related to poor handling of the pipe. But in the event your line loses pressure there are several ways to locate the leaks.

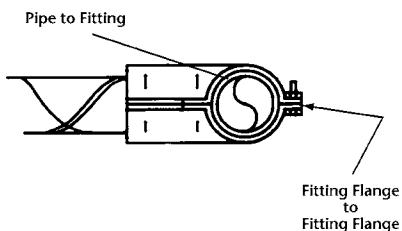
1. Be sure you soak all primary fitting and pipe joints with a detergent/water solution before closing up the secondary containment.
2. Be sure you soak all secondary containment fitting with a detergent/water solution.
3. Helium and other detectable gases are also an alternative where sniffers can be used.
4. In the event you have a leak isolated to a line and you cannot find it, it is recommended that you test the line in sections to find the leak. Once you have the correct pipe section, cut it out and replace it.
5. An alternative method to finding a leak in a size-over-size system is to fill the secondary containment line with water, pump 10 psig max air through the primary and look for air bubbles through the secondary containment pipe wall.

## Repair Procedures

Leaks can occur if secondary containment joints are not properly bonded. Upon completion of required repairs and before putting the line back into service, always pressure test the repair work according to the procedures to assure the integrity of the system. For damaged pipe and for leaking joints, the recommended repair methods are listed below.

### Replacing Leaking Two-Piece Secondary Containment Fittings

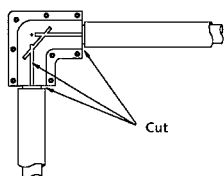
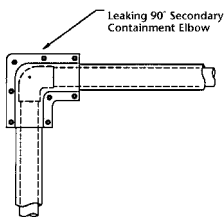
Do not use this procedure for containment crossovers.



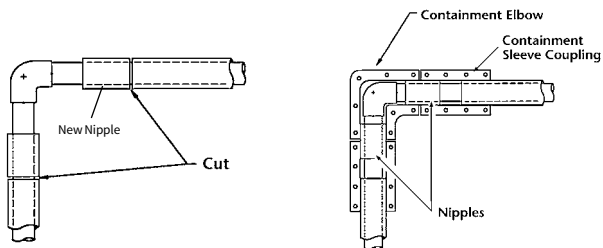
**Figure 2.10**  
Example: 90° Secondary Containment Elbow

When cutting out and replacing a secondary containment fitting, do not cut the internal primary product pipe.

1. Dissect the secondary containment fitting and secondary containment pipe around its circumference as shown by the arrows. Remove the containment elbow.
2. Create a pipe nipple at least 7" (180 mm) long on each side of the joint by making another cut around the circumference of the containment pipe.
3. Using a sander, coarse file, or 60-80 grit Emery cloth, remove surface gloss from both ends of the nipples and the containment pipe. Sanded area must be a minimum of 3" (75 mm) in length.



- Position the nipples between the new containment elbow and containment sleeve couplings. It may be necessary to remove additional sections of the containment pipe to provide clearance for the coupling.
- Bond the elbow and containment sleeve couplings into place according to instructions.



## Repairing Minor Damage to Pipe

Follow the pipe patching instructions in Section 1 of this manual when the damaged area is two inches (50 mm) or less in diameter.

## Repairing Minor Damage to Red Thread IIA and Dualoy Fittings

Small repairs (pinhole leaks and leaks up to 1" (25 mm) in diameter) using 8088 Repair Kit:

- Take pressure off the system and dry the area around the leak.
- Sand an area 3" (75 mm) minimum on each side of the leak.
- Cut three 3" x 3" (75 x 75 mm) patches from the glass supplied with the 8088 repair kit.
- Mix adhesive per instructions supplied in the kit.
- Paint adhesive on the sanded area of the fitting.
- Apply the first layer of glass and wet out with adhesive. The glass may be wet out before it is applied to the leak area.
- Repeat the previous step and apply another layer of glass.
- Cure per the time listed in the adhesive kit instructions.

## Flange Section or Joint Leak Repairs Using 8088 Repair Kit

(Overwrapping Entire Fitting)

1. Take pressure off the system and dry the area around the leak.
2. Grind or cut flange sections off the clamshell secondary containment fitting and sand flush with the fitting body.
3. If needed, mix adhesive with filler to grout in any gaps or voids in the bond line or to create a smooth wrapping surface.
4. Per instructions in the 8088 repair kit, apply adhesive to the sanded area. Wet out glass and wrap around the fitting as though it were a section of pipe, centering the first layer over the joint and extending 2" (50 mm) past the end of the fitting onto the pipe. Apply tension to squeeze adhesive through the glass layer. For elbows and tee, slits may have to be cut in the center section for glass to lie flat.
5. Repeat previous step on the center of the joint and then the other side of the fitting extending 2" (50 mm) over the end of the fitting. When starting the glass, overlap the first wrap a minimum of 2" (50 mm).
6. Repeat two previous steps until three layers of glass have been placed over the fitting.
7. Cure per the time listed in the adhesive kit instructions.

## Repairing Extensive Pipe Damage to Red Thread IIA and Dualoy 3000/L Containment Pipe

When damage is less than 2" (50 mm) long but more than 2" (50 mm) around the circumference of the pipe, the following repair procedures should be followed. If the pipe is buried, excavate a working area large enough to allow for repairs to be made. Use a secondary containment sleeve coupling to make this type repair. Containment sleeve couplings are 14" (350 mm) long.

**CAUTION:** When cutting out extensive damage in the containment pipe (only), be extremely careful not to damage the internal product piping.

1. After cutting free the damaged section of containment pipe (no more than 7" / 175 mm) long, slit the section of pipe in half and remove.

2. Using a sander, coarse file or 60-80 grit Emery cloth, remove surface gloss from both ends of the remaining pipe. Sanded area must be a minimum of 3" (75 mm) in lengths. If contaminated, clean the sanded surfaces.
3. Mix the 8000 Series or PSX-34 adhesive with filler. Assemble and bond the containment sleeve coupling into place and heat cure the bond.
4. After the repaired section has cured, pressure test the system following the procedures listed in testing.
5. If damage is beyond these repair procedures, immediately contact your local distributor or sales representative for assistance.



# Section 3

## Dualoy 3000/LCX Coaxial Pipe

Cutting

Tapering/Scarfig with Power & Manual Tools

Sump Penetration Fitting Instructions

Bonding Containment Piping

Adhesive for Containment Piping

Terminating the Secondary Containment

Repair Procedures

Primary System Testing

# Dualoy 3000/LCX Coaxial Pipe

Dualoy 3000/LCX pipe and fittings are manufactured from fiberglass reinforced, thermosetting, aromatic amine cured epoxy resins, as are Red Thread IIA and Dualoy 3000/L pipe. The containment jacket on the pipe is coaxial and in close proximity to the primary pipe, separated by a thin layer of glass beads. The two layers do not move relative to each other so the pipe handles, effectively, like a single piece. The containment over the fittings is made by applying matched two-piece clamshell fittings over the primary fitting connecting the pipe containment jackets. The primary piping and fittings are joined using the same strong reliable bonded joint as in Dualoy 3000/L single wall piping.

Installation of Dualoy 3000/LCX pipe follows the same basic principles as that of Red Thread IIA and Dualoy 3000/L piping, as defined in this booklet. The same primary fittings are used for Red Thread IIA, Dualoy 3000/L and 3000/LCX pipe and the same cutting and tapering instructions apply. There is an added note that when tapering the primary pipe of Dualoy 3000/LCX pipe, care needs to be taken not to damage the secondary jacket.

## Cutting

Use a fine-blade hacksaw, radial cut-off saw or circular saw with abrasive wheel to cut pipe in the field. The cut end must be square to within 3/16 inch (5 mm). Hold pipe securely for all cutting and tapering. When using a pipe vise, always wrap the pipe with a protective material such as a 1/4 inch (6 mm) thick rubber pad. Take care not to damage or over-deflect the pipe when tightening the vise.

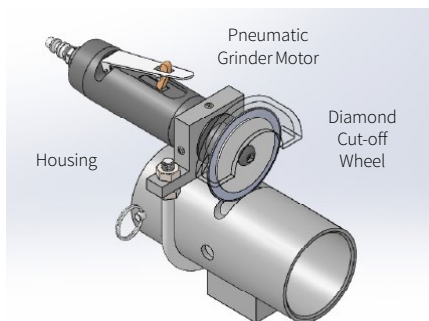
## Jacket Removal

Remove containment with jacket cutting tool as shown in Figures 3.1 and 3.2. The jacket cutting tool is used to quickly remove the containment layer from the end of the pipe to expose the primary when field cuts are needed. The tool provides a square finished edge to the containment. The tool consists of a pneumatic grinder equipped with a diamond coated cut off wheel. It is adjustable to allow it to be set at the desired depth to cut through the containment without any risk of cutting into the primary pipe. The jacket cutting tool can either be clamped into a vise or can be hand operated if the pipe is clamped into a pipe vise.

- Remove the containment by activating the grinder and inserting the end of the pipe into the housing (single size tool) or onto the guide rods (universal tool). Note: Periodically check guide rods of universal jacket cutter for nick, burrs, gouges, etc. that could damage the inner liner of the pipe. Remove these prior to use.
- Push the pipe into (or onto) the tool to cut a longitudinal groove in the containment.
- When the end of the pipe reaches the pin, rotate the pipe (or tool), cutting the containment circumferentially.
- When cutting the jacket of a pipe to be used with a termination sleeve, a longer cut of jacket is needed to allow enough room to bond the primary pipe to both the termination sleeve and a primary fitting. Minimum dimensions are shown in the Table 3.1.
- Rotate back to the starting position and remove the pipe from the tool, letting the rotating grinding wheel track back through the cut made when the pipe was put in/on the tool.
- Physically remove the containment layer by prying it open slightly and pulling it off the primary. Use care to avoid damage to the primary pipe during this operation.

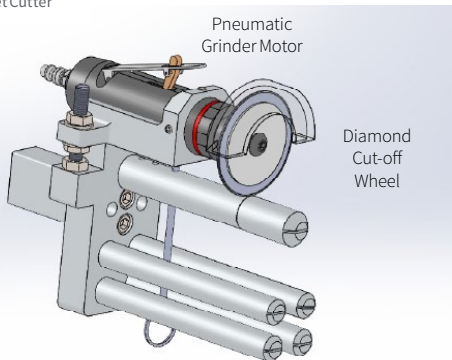
**NOTE:** The cut off wheel will gradually wear and need adjustment to cut at the proper depth. To adjust, set the depth so that the wheel cuts just to the tape layer (outer edge of the layer of glass beads) and not into the layer of glass beads. This will minimize wear on the wheel.

**Figure 3.1**  
Jacket Cutter



**NOTE:** Safety guard is omitted for clarity

**Figure 3.2**  
Universal Jacket Cutter



**NOTE:** Pin and rods are adjustable for 2", 3" and 4" sizes. Pin must be in proper position for size to give correct depth of cut. For more details, see tool instructions.

**Table 3.1**

Containment Jacket Removal Dimensions

Pipe Size		Containment removed to bond into a fitting		Containment removed to use termination sleeve	
in	mm	in	mm	in	mm
2	50	2.75	70	4.50	114
3	80	2.75	70	4.50	114
4	100	3.50	91	5.75*	146

\* Adjust grinder motor position by loosening set screw, move motor 1/4" (32 mm) then tighten set screw. Adjust when finished making termination cuts.

## Tapering and Scarfing With Power Tools

The 3000 series power tool is recommended for Dualoy 3000/LCX pipe. It is specifically designed by NOV Fiber Glass Systems to taper the primary pipe and scarf the containment pipe. Tools are available from other manufacturers but they only taper the primary pipe. They are not designed to provide a powered scarf to the containment pipe. Pipe tapered with these tools should be periodically checked against a factory taper for taper length and taper angle. The correct mandrel must be used for Dualoy pipe. Refer to tool instructions for proper procedures.

## Tapering and Scarfing With Manual Tools

For situations where electricity isn't available, use the Ratchet Pro Taper Maker fitted with the special blade designed for Dualoy 3000/LCX primary tapers. Scarfing must be done with 60 to 80 grit Emery cloth or sandpaper, when done manually.

## Piping System Layout - Sump Penetration Fitting Installation

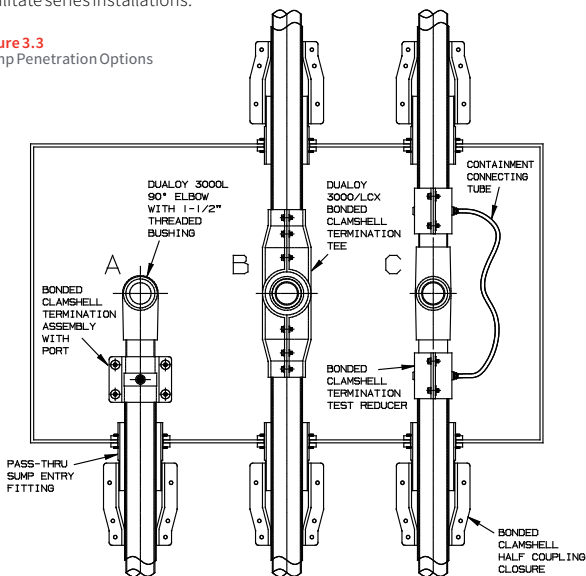
Dualoy 3000/LCX was designed with the idea that fiberglass pipe could be installed through the sumps in series. In order to achieve this, sump penetration fittings are used to allow the pipe to pass through the sumps to the next sump.

- Typical sump penetration detail for a system piped in parallel or at last sump of a system piped in series.
- Typical sump penetration detail for a system piped in series and utilizing termination tees.
- Typical sump penetration detail for a system piped in series using termination sleeves and jumper hose.

**NOTE:** Low test pressure needed if connecting tube is pressurized.

**NOTE:** 24 inch (600 mm) minimum width recommended on dispenser sumps to facilitate series installations.

**Figure 3.3**  
Sump Penetration Options

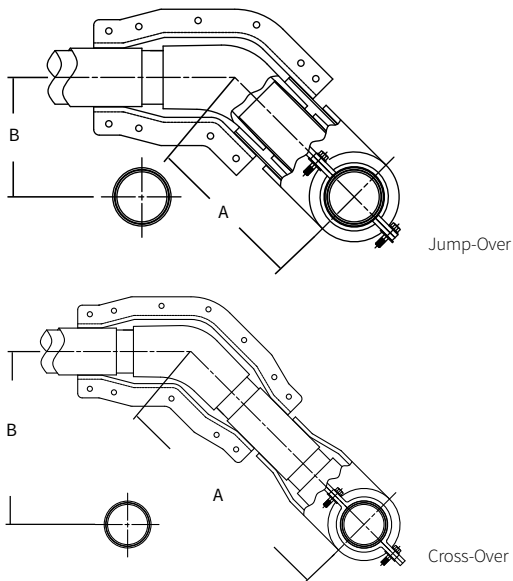


## Jump-overs and Crossovers

Assemblies for crossing lines can be made in one of two ways. For lines where the tee and 45° elbow need to be very close (a jump-over), the clamshell fittings can be cut at the beginning of the tapered portion on the branch of the tee and one leg of the elbow. A piece of single wall pipe of the next larger size can be used to connect the clamshell fittings (see Figure 3.4 for Jump-Over). For lines where there is sufficient distance between the tee and 45° elbow to allow for the full clamshell fittings, the crossover can be made by simply bonding the fittings and clamshells to a piece of standard coaxial pipe (see Figure 3.4 for Cross-Over)

Jump-over assembly made with next larger size single-wall containment pipe and clamshell fittings cut at start of taper to allow minimum length as summarized in Tables 3.2 and 3.3.

**Figure 3.4**  
Jump-Over / Cross-Over



**NOTE:** Cross-over assembly made with LCX pipe and full clamshell fittings for installations where longer length is allowed or needed.

**Table 3.2**

Jump-Over / Cross-Over Minimum Lengths (A)

Pipe Size		Minimum Lengths (A)			
		Jump-Over		Cross-Over	
in	mm	in	mm	in	mm
2	50	7 ½	190	12 ⅝	320
3	80	9 ¾	250	14 ¾	375
4	100	10 ¼	260	16 ½	420

**Table 3.3**

Jump-Over / Cross-Over Minimum Lengths (B)

Pipe Size		Minimum Lengths (B)			
		Jump-Over		Cross-Over	
in	mm	in	mm	in	mm
2	50	5 ¼	135	9	227
3	80	6 ⅞	175	10 ½	265
4	100	4 ¼	185	11 ⅝	295

## Reducers

The Dualoy 3000/LCX Coaxial Piping System can be reduced from 3" to 2" (80-50 mm), 4" to 3" (100-80 mm) and 4" to 2" (100-50 mm). See Figure 3.5.

Mark the "X" Dimension on the outside of smaller secondary prior to bonding primary:

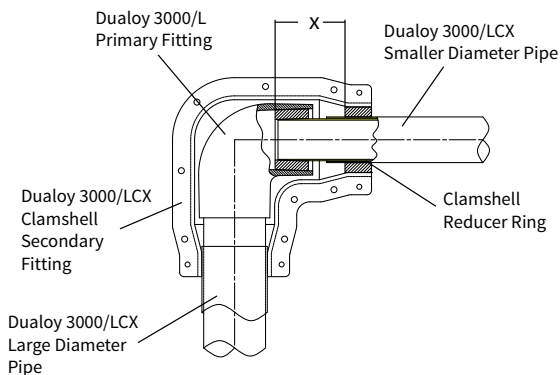
- Sand bonding surface of jacket.
- Apply adhesive and place clamshell reducer ring in place on smaller pipe containment layer. Allow adhesive to cure.
- After all primary bonding, curing and testing is complete, bond clamshell containment fitting in place on larger secondary pipe and clamshell reducer ring.

**Table 3.4**

Dualoy 3000/LCX Reductions

Reducer	(X)
3" to 2"	3 ¾
4" to 3"	4 ¼
4" to 2"	4 ¼

**Figure 3.5**  
Reducer



## Adhesive for Containment Piping:

PSX-34 adhesive is recommended for secondary containment.

- Bond containment only after primary lines have been tested, inspected and approved.
- All bonding surfaces must be free from water, soap, oil, grease, dirt and other contaminants and should be sanded before applying adhesive.
- Apply a uniform coating of adhesive to the flanges of each of the containment fitting halves and to the curved surface of the fitting where the pipe fits. Also apply adhesive to the outside of the containment pipe where it is scarfed and the fitting will be in contact. Keep adhesive off the last half inch of the pipe jacket when applying it to the pipe.

**Table 3.5**

Containment Bonds per Kit<sup>(1)</sup>

Pipe Size		Adhesive Kit Size		
in	mm	3 oz. <sup>(2)</sup>	5 oz. <sup>(2)</sup>	8 oz. <sup>(2)</sup>
2	50	1	3 <sup>(3)</sup>	4
3	80	1 <sup>(3)</sup>	1	2
4	100	½	½	1

<sup>(1)</sup> The average number of primary system bonds obtainable by experienced crew at 75°F.

<sup>(2)</sup> Available in 10-pack kits.

<sup>(3)</sup> Fewer bonds on tees would be typical, more for termination sleeves.



- Place the containment half-shells around the primary fitting. Use the half with the pre-inserted nuts as the bottom half to allow easier access to the bolt heads when tightening. Once in place insert and begin threading each bolt into the pre-inserted nut by hand. A nut driver or a single hand-held power tool, such as a cordless drill, can be used to assemble the bolts. If a power tool is used to tighten the bolts, confirm tightness of each bolt with a nut driver. Tighten bolts evenly in staggered sequence started with inner radius bolts first.

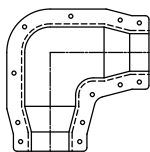
**NOTE:** The recommended maximum bolt torque is 8 ft•lb.

## Bonding Containment Piping

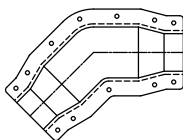
### Joint Preparation:

Inspect all sealing surfaces to ensure they are free of any foreign material such as dirt, sand, or adhesive. Inspect all bonding surfaces to ensure there are no cuts, scratches, or nicks which could prevent the joint from sealing properly.

**Figure 3.6**  
Dualoy 3000/LCX Secondary Containment Fittings



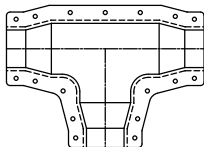
90° Elbow



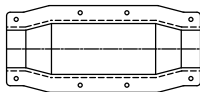
45° Elbow



Termination  
Fitting



Tee



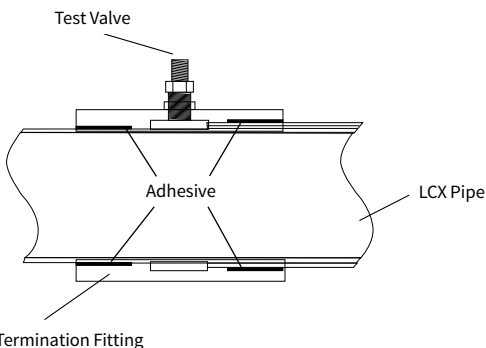
Containment Coupling

## Terminating the Secondary Containment

### Clamshell Termination with Test Port

Apply adhesive to all bonding surfaces after sanding, as described above. DO NOT put any adhesive in the center portion of the termination sleeve body. Position the clamshell termination with test port over the cut jacket so that the shoulder in the assembly fits against the cut jacket end. Particular care must be given to assure excess adhesive is not used as it may cause sealing of the containment. See Figure 3.7.

**Figure 3.7**  
Clamshell Termination with Test Port



**NOTE:** Dualoy 3000/LCX molded termination assembly to seal off secondary containment.

**NOTE:** 2" (50 mm) is available with or without test valve; 3" and 4" (80 and 100 mm) are available only with test valve.

### Terminating a Containment Fitting Inside the Sump

The means of terminating the containment on the branch leg of a tee (series layout) or the downstream leg of an elbow (parallel layout or last sump of a series layout) is done with a bonded termination adapter. The adapter is bonded to the exterior of the primary fitting leg to be terminated, prior to the clamshell containment fitting being placed on the assembly.

- Lightly sand the outside surface of the leg of the primary fitting on which the termination is to be bonded.
- Abrade the inner surface of the termination adapter also, to provide a fresh surface to which to bond.
- Cut the tapered end portion of the containment fitting leg which is to be terminated. Abrade the inner surface of the shortened leg of the containment fitting to prepare it for later bonding.
- Apply a moderate coating of adhesive to outer surface of the primary fitting and the inner surface of the termination adapter. Keep the outer surface of the adapter dry and free of adhesive.
- Fit the adapter onto the primary fitting.
- Dry fit tapered Dualoy 3000/LCX pipe leg(s) into the bell ends of the primary fitting which is not terminated, if this procedure is done prior to bonding the primary fitting into the system (recommended).
- Place the clamshell containment fitting over the primary fitting-adapter assembly and hold in place with bolts while the adhesive cures. This will assure proper alignment of the adapter for final assembly. Care should be taken to assure adhesive does not touch the clamshell fitting at this point as it is to be removed when the adhesive between the primary fitting and the adapter is cured.
- Once the adhesive has cured, remove the bolts and the clamshell fitting. If this procedure was done prior to bonding the primary fitting into the system, install according to standard procedures.
- Use the prepared clamshell fitting to close the containment system when primary testing and inspection is done.

## Repair Procedures

Dualoy 3000/LCX is very resistant to impact damage. It can be damaged by paving stakes, large concrete pieces or other hazards. In the event of damage, the pipe can be repaired using these procedures.

Usually the damaged area is obvious. If the exact location of the damage cannot be determined, it may be necessary to replace that full length of pipe. Standard leak detection methods (soapy water) can be applied progressively along the length of pipe to locate the damaged or defective section.

If the primary pipe is leaking at an unknown location, the cut ends of the jacket at each end of each piece of pipe can be soaped to locate the leak (if containment fittings are not bonded in place). If the containment pipe is leaking, the surface can be soaped.

**Minor damage to primary pipe** (Isolated to less than one inch (25 mm) of pipe length)

- Cut out the damaged pipe.
- Remove the jacket and taper each of the ends of the remaining pipe
- Assemble primary coupling following standard installation practices.
- Assemble containment coupling following standard installation practices.

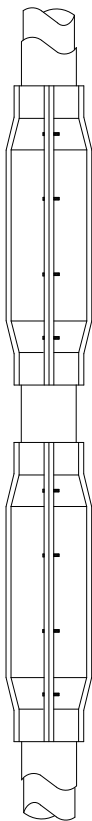
**Major damage** (greater than one inch (25 mm) of pipe length)

- Remove at least 15 inches (380 mm) of pipe length or the full length of damaged pipe if damaged area is greater.
- Remove the jacket and taper each of the ends of the remaining pipe
- Dry fit two couplings and intermediate pipe nipple into the gap.
- Proceed as above for each end of repair area. Finished repair is as shown on Figure 3.8.

**Minor damage to containment pipe only** (Isolated to less than one inch (25 mm) of pipe length)

- Sand area around damaged area - approximately one inch (25 mm) in all directions.
- Recover cut jacket section from jacket cutter, remove tape and sand from inner surface. Sand inner surface.

**Figure 3.8**  
Finished Repair



**NOTE:** Completed repair section using Dualoy 3000/LCX coupling assembly

- Apply thin coating of adhesive to sanded surfaces.
- Wrap jacket section over pipe and secure in place until adhesive cures.
- Once the pipe is buried and the site is paved, repair requirements are extremely rare for Dualoy 3000/LCX. If the pipe does become damaged, sections can be isolated and tested between sumps to locate the problem area. Pavement may need to be removed to access the damaged pipe.
- When applying adhesive, be sure to coat all cut edges of pipe.

### **Dualoy Repair Coupling**

A Repair Coupling can be used to repair Dualoy 3000/LCX similar to the methods described in Section 1 of this manual. Contact NOV Fiber Glass Systems for additional details.

## **System Testing**

### **Safety Precautions**

NOV FIBER GLASS SYSTEMS SHALL NOT BE LIABLE UNDER ANY WARRANTY, CONTRACT, OR IN TORT, FOR ANY RESULTING INJURY TO PERSONNEL OR DAMAGE TO EQUIPMENT, PIPE, OR OTHER PERSONAL PROPERTY FOR FAILURE TO FOLLOW THE PROCEDURES AND COMPLY WITH THE PRECAUTIONS SET FORTH.

As in any system where pressure is employed, adequate safety precautions should be exercised.

NOV Fiber Glass Systems does not recommend testing any installation with air or gas because of the safety hazards created. The light weight, flexibility, and elasticity of fiberglass pipe create different conditions than are present with steel pipe. If a failure should occur while testing fiberglass pipe with air or gas, the system would be subject to considerable whipping and other shock-induced conditions due to the sudden release of stored energy. The violent release can cause severe personal injury or death to personnel in the area and can also cause damage to the pipe or other property.

If a line is tested with air or gas, NOV Fiber Glass Systems will not be responsible for any resulting injury to personnel or damage to property, including the pipe. Such testing is done entirely at the risk of those involved.

## Testing General

Installed pipe systems should be tested prior to use to assure soundness of all joints and connections. Locate pressure gauge in close proximity to the pressurizing equipment, not directly on the piping system. Below are general recommendations:

- Plan tests carefully and carry them out with all due precautions.
- Pressurizing equipment should be suited to the size of the system and the pressure required and should be operated by qualified and experienced personnel only.
- Pressure sources should be capable of approaching test pressure gradually.
- Use gauges with full-scale reading of no more than twice the test pressure. Do not use a 100-psi (0.69 MPa) gauge for a 10 psi (0.069 MPa) test. Use reliable gauges calibrated against a dead weight tester and zeroed for atmospheric pressure.
- Isolate tanks from the piping when pressure testing.
- Do not exceed 150% of system rating. Check the pressure rating of all the components of the system, not just the pipe, because hoses and flexible connectors are almost always rated lower than the pipe.
- Do not adjust fittings while system is under pressure. If threaded adapters or bushings leak, release the pressure before attempting to tighten.

## Dualoy 3000/LCX Air Testing Considerations

Plan tests carefully and carry them out with all due precautions. Pressure test the primary piping as described in the System Testing section of Section 1. Pressure sources should be capable of approaching test pressure gradually.

Pneumatic testing at approximately 10 psi (0.069 MPa) is recommended and is the preferred method of testing containment piping.

## Provisions for testing and monitoring

- The clamshell termination sleeves with test valves are equipped with a 1/4 inch (6 mm) Schrader valve which can be used to attach pressurizing equipment. It may be necessary

to remove the internal valve prior to attaching pressurization equipment. Use proper tool to do so.

- Should gauge readings fail to remain stable and the testing is being done pneumatically, use a soap solution to locate leakage. Schrader valve core should be removed after testing is accomplished.

### **Simultaneous Testing**

Simultaneous testing of the primary and bonded containment section will not normally be done as the containment system will not be closed until the primary has passed testing. However, it may be advisable to maintain a pressure on the primary during testing of the containment in order to precisely test both systems. If this is done, the pressure in the primary should be at least 10 psi (0.069 MPa) different than the containment test pressure (higher or lower). If a leak does exist in the primary, it will be very evident due to change in pressure in the relatively low volume containment system.

## Definition of Terms

**BxS** - Bell (female) x spigot (male) tapered joint.

**Bond Line** - Area where two surfaces are bonded together with adhesive.

**Closed Secondary Containment Piping System** - A secondary piping system with ends normally closed at the tank and sump with a minimum rated pressure of 50 psig (.350 MPa).

**Cocked Joint** - Appearance of BxS joint that is improperly aligned.

**Cool Weather Conditions** - Below 65°F (18°C).

**Cure Time** - Time for a joint to completely cure after it is bonded.

**Damaged Pipe** - Pipe that has been affected by excessive impact, external or bending loads.

**Glue Line** - See bond line.

**Improperly Cured Joint** - Joint that is not cured due to poor adhesive mixing or inadequate heating in cool weather

**Joint Backout** - A spigot that backs out of a bell due to incomplete lock up or movement at the other end of the pipe.

**Lock Up** - Spigot is fully engaged with the bell until there is resistance to pivot action in the joint.

**Machined Surface** - Area of pipe or fitting that is machined to remove the surface gloss so that it may be bonded.

**Matched Taper** - The matching tapers on a BxS or T.A.B. joint.

**Mechanical Locking** - See lock up.

**Open Secondary Containment Piping System** - A secondary piping system with ends normally open at the sump and a minimum rated pressure of 5 psig (0.035 MPa).

**Pot Life** - Time allowed to make bonds with adhesive after mixing.

**T.A.B.** - Threaded and Bonded - Tapered joint with shallow threads to prevent joint back out.



## Installation Check List

Installation Checklists are available from NOV Fiber Glass Systems. These are great tools to make sure installation basics are understood and followed. In addition, the completed checklist is an excellent project closeout document for the Owner and Installer. Contact your local representative or visit our website for copies of the Installation Checklist.

	Installer's Foreman	Owner/ Operator Rep.
<p><b>PRE-INSTALLATION CHECKLIST</b> (Indicate date verified after each item.) Installer shall show evidence that:</p> <ol style="list-style-type: none"> <li>1. He/She is licensed or certified by the state implementing agency (where applicable).</li> <li>2. Each bonder on site is current in his/her manufacturer's training (recommended every 3 years).</li> </ol>		
<p>Installer has current manufacturer's installation instructions:</p> <ol style="list-style-type: none"> <li>1. Installation manual number</li> <li>2. Manual Dated</li> </ol>		
<p>Pipe &amp; Fittings have UL (Underwriters' Laboratories) or ULC (Canada) label. NOTE: label may be located on the box for some fittings.</p>		
<p>Proper Tools and adhesive available per manufacturer's instructions.</p>		
<p><b>Pipe &amp; Fittings inspection:</b></p> <ol style="list-style-type: none"> <li>1. Impact or puncture....Cut out. See Footnote (1) for repairs.</li> <li>2. Damaged tapers...Cut off and re-taper.</li> <li>3. Check bonding surfaces for ultraviolet weathering degradation.</li> <li>4. Replace any missing pipe end caps to protect tapers until time to install.</li> </ol>		

	Installer's Foreman	Owner/ Operator Rep.
<p><b>Trench:</b></p> <ol style="list-style-type: none"> <li>1. Allow for minimum of 6" bedding material.</li> <li>2. Have required slope per owner's design documents or local requirement.</li> <li>3. Width: Allow for 4" minimum separation between pipes and 6" minimum from trench walls.</li> </ol>		
<p><b>Approved backfill (NO native soil)</b></p> <ol style="list-style-type: none"> <li>1. Provide backfill per owner's design documents; or at a minimum:</li> <li>2. Clean washed sand, or</li> <li>3. Pea gravel - <math>\frac{1}{8}</math>" to <math>\frac{3}{4}</math>" particle size, or</li> <li>4. Refer to Footnote (1) for other backfill materials.</li> </ol>		
<p><b>INSTALLATION PROCEDURES</b> (Indicate date verified after each item.)</p> <ol style="list-style-type: none"> <li>1. 6" of approved bedding material.</li> <li>2. Dry fit system prior to adhesive bonding. See Footnote (1).</li> <li>3. Heat assist required for adhesive curing when temperature is below 50°F (10°C). See Footnote (1).</li> <li>4. A minimum separation of 4" between pipe runs and 2½" on crossovers.</li> <li>5. Bedding/backfill supports pipe completely on runs and crossovers.</li> <li>6. Minimum of 6" approved backfill cover material or more as required by local authorities or design documents.</li> <li>7. If surface is unpaved, a minimum of 18" of approved backfill (for 2" pipe) is required. See Footnote (1).</li> </ol>		

	Installer's Foreman	Owner/ Operator Rep.
<p><b>INSPECTION AND TESTING</b> (Indicate date verified after each item.)</p> <ol style="list-style-type: none"> <li>1. Cocked joints (misaligned tapers). See Footnote (2).</li> <li>2. Joint Back off. See Footnote (2)</li> <li>3. Check for proper cure of adhesive bond. See adhesive kit instructions.</li> <li>4. Test piping system in accordance with manufacturer's recommendations or local requirements. See Footnote 3.</li> <li>5. Secondary containment piping, See Footnote (1).</li> </ol>		

**Footnotes:**

**(1)** See Installation Manual INS1280.

**(2)** Connections must be removed and replaced

**(3)** It is recommended that after the initial system test has been completed, a low pressure (25 psig maximum) be kept on tested pipe during the completion of the installation. If pressure loss occurs, repairs can be accomplished before system goes into service.

**CAUTION:** Testing with compressed air is extremely dangerous and is not recommended. If compressed air is used, proceed with extreme caution and follow safety precautions stated in the manufacturer's instructions. Isolate piping system from tank prior to testing.

## Important Notice

1. NOV Fiber Glass Systems' checklist addresses subjects of a general nature associated with the installation of Red Thread IIA, Dualoy 3000/L and Dualoy 3000/LCX piping as a part of underground storage tank (UST) systems. Federal, State and local laws and regulations governing such installations and UST systems should be reviewed. The types of work covered by the checklist should be performed by trained installers.
2. Red Thread IIA, Dualoy 3000/L and Dualoy 3000/LCX UL/ULC Listed fiberglass pipe installation, when performed by manufacturer-trained installers in accordance with the

manufacturer's installation instructions and verified by the installer and the owner/operator representative on an installation checklist, is a method to demonstrate compliance with Federal, State and local laws and regulation governing such installations. The use of non-qualified personnel or any deviations from the recommended procedures could result in damage or leakage of the system.

3. When the installation checklist is complete, one copy should be retained in the installer's files and one copy on the owner/operator's file.
4. NOV Fiber Glass Systems is not undertaking to meet the duties of underground storage tank system owner/operators, employers, manufacturers, or supplier to warn and properly train and equip their employees, and others exposed or in contact with fiberglass piping and materials, concerning their obligations under Federal, State or local laws or regulations, as well as health and safety risks and precautions.
5. Information concerning safety and health risks and proper precautions with respect to particular materials and conditions should be obtained from the manufacturer or supplier of the material, or the applicable material safety data sheet.
6. THE INSTALLATION CHECKLIST MAY BE USED BY ANYONE DESIRING TO DO SO. EVERY EFFORT HAS BEEN MADE BY NOV FIBER GLASS SYSTEMS TO ASSURE THE ACCURACY AND RELIABILITY OF THE INFORMATION IT CONTAINS. HOWEVER, THE COMPANY MAKES NO REPRESENTATION, WARRANTY, OR GUARANTEE IN CONNECTION WITH THIS CHECKLIST AND HEREBY EXPRESSLY DISCLAIMS ANY LIABILITY OR RESPONSIBILITY FOR LOSS OR DAMAGE, INCLUDING PERSONAL, INJURY OR PROPERTY OR OTHER DAMAGES OR WHATEVER NATURE, RESULTING FROM ITS USE OR FOR THE VIOLATION OF ANY FEDERAL, STATE, OR LOCAL LAW OR REGULATION WITH WHICH THIS CHECKLIST MAY CONFLICT.
7. If you have questions concerning the proper installation of Red Thread IIA, Dualoy 3000/L and Dualoy 3000/LCX fiberglass piping, contact NOV Fiber Glass Systems.



Notes: \_\_\_\_\_

\_\_\_\_\_

\_\_\_\_\_

\_\_\_\_\_

\_\_\_\_\_

\_\_\_\_\_

\_\_\_\_\_

\_\_\_\_\_

\_\_\_\_\_

\_\_\_\_\_

\_\_\_\_\_

\_\_\_\_\_

\_\_\_\_\_

\_\_\_\_\_

\_\_\_\_\_

\_\_\_\_\_

\_\_\_\_\_

\_\_\_\_\_

\_\_\_\_\_

\_\_\_\_\_

\_\_\_\_\_



Notes: \_\_\_\_\_

---

---

---

---

---

---

---

---

---

---

---

---

---

---

---

---

---

---

---

---

---

---

---

---

---

## **Fiber Glass Systems**

17115 San Pedro Avenue, Ste 200  
San Antonio, Texas 78232 USA  
Phone: 210 477 7500 | Fax: 210 477 7560

National Oilwell Varco has produced this brochure for general information only, and it is not intended for design purposes. Although every effort has been made to maintain the accuracy and reliability of its contents, National Oilwell Varco in no way assumes responsibility for liability for any loss, damage or injury resulting from the use of information and data herein nor is any warranty expressed or implied. Always cross-reference the bulletin date with the most current version listed at the web site noted in this literature.

© 2016 National Oilwell Varco All Rights Reserved  
INS1280ENG October 2016

---

## **Fiber Glass Systems**



[nov.com/fgs](http://nov.com/fgs)