

2016 Capital Project - Phase II

<u>Category:</u>	Elementary, Pre Schools, High Schools, Junior High Schools, Transportation Terminals, Warehouses	<u>Project ID #:</u>	1004604953
<u>Street Address:</u>	Multiple Locations Newark Valley NY 13811	<u>Confirmed Value</u>	\$9,300,000.00
<u>County:</u>	Tioga	<u>Stage:</u>	BIDDING - Biddate Set
<u>Bid Date:</u>	2/1/2018 , 03:00PM		
<u>Architect:</u>	Keystone Associates Architects Engineers & Surveyors LLC		
<u>Documents Available:</u>	Specs, Addenda available in Insight	Plans available from Keystone Associates Architects Engineers & Surveyors LLC	
<u>Last Update:</u>	1/26/2018	Plan Addenda, Spec Addenda were Added/Updated	

Personal Notes

User	Note	Update Date	Private?
Adam Sweet	1,000 GALLON OWS HIGHLAND TANK HTC-G DW OR EQUAL	1/29/2018	False

Project Events

Event	Date	Details
Bid Date	2/1/2018 , 03:00PM	Owner will receive sealed lump sum bids at Newark Valley Central School District, District Office, 68 Wilson Creek Road, Newark Valley, New York 13811. Bids will be thereafter publicly opened and read aloud.
End Date	3/16/2018	
Pre-Bid Meeting	1/15/2018 , 09:00AM	A Prebid meeting for all bidders will be held starting at the Middle School, 88 Whig Street, Newark Valley, NY. Prospective prime bidders are requested to attend.
Start Date	3/1/2018	Actual Start Date

Notes

Scope

Demolition, site work, new construction, renovation and addition to a mixed-use development in Newark Valley, New York. Completed plans call for the addition of a educational facility; for the demolition of a educational facility; for the construction of a educational facility; and for the renovation of a educational facility. 1. Construction of new Transportation Building, which includes, site work, general construction, plumbing, mechanical and electrical work; 2. Renovation to existing Bus Garage; 3. District wide security camera and data wiring upgrade; 4. Renovations to existing kitchen and mechanical work for geothermal system at Nathan T. Hall Elementary School and repointing brick. 5. Repointing of bricks, kitchen and multi-purpose room renovation and mechanical work for geothermal system at Middle School; 6. Mechanical work at High School and addition to existing Storage Building. Construction Contract: Bids will be received for the following Work: 1. Single Contract Project consisting of the following prime contracts: a. Contract No. 1 - Site Construction. b. Contract No. 2 - General Construction. c. Contract No. 3 - Plumbing Construction. d. Contract No. 4 - Mechanical Construction. e. Contract No. 5 - Electrical Construction. f. Contract No. 6 - Food Service Construction. Owner will consider bids prepared in compliance with the Instructions to Bidders Bid security shall be submitted with each bid in the amount of the bid amount. No bids may be withdrawn for a period of 45 calendar days after opening of bids. Owner reserves the right to reject any and all bids and to waive informalities and irregularities. Bidders have the option to provide Dataflow with Bidder's UPS or FedEx shipping account number to expedite delivery of documents. B. Online Procurement and Contracting Documents: Obtain access by contacting Dataflow, Inc., (607) 772-2001. Online access will be provided to all registered bidders and suppliers. C. Viewing Procurement and Contracting Documents: Examine at the locations below: Bidders who have paid the aforesaid deposit for an entire hard copy set of Bidding and Contract Documents; have submitted a Bid with required bid security; and return such sets including all addenda, to Dataflow, Inc. in GOOD CONDITION within thirty (30) days after the opening of Bids, shall receive a refund of the full amount of such deposit for one (1) set. Successful bidders shall begin the Work within fifteen (15) calendar days of the Notice to Proceed and shall complete the Work within the contract time. Bidders must be properly licensed under the laws governing their respective trades and be able to obtain insurance and bonds required for the Work. A Performance Bond, separate Labor and Material Payment Bond and Insurance in a form acceptable to Owner will be required of the successful Bidder.

Notes

Development include(s): Site Work, Addition, Demolition, Renovation, New Construction Bid Date: 02/01/2018 03:00PM Owner will receive sealed lump sum bids at Newark Valley Central School District, District Office, 68 Wilson Creek Road, Newark Valley, New York 13811. Bids will be thereafter publicly opened and read aloud. Pre-Bid Meeting: 01/15/2018 09:00AM A Prebid meeting for all bidders will be held starting at the Middle School, 88 Whig Street, Newark Valley, NY. Prospective prime bidders are requested to attend.

Additional Details

<u>Listed On:</u>	1/11/2018	<u>Floor Area:</u>	
<u>Contract Type:</u>		<u>Work Type:</u>	Addition/Alteration
<u>Stage Comments 1:</u>		<u>Floors Below Grade:</u>	
<u>Stage Comments 2:</u>		<u>Owner Type:</u>	City
<u>Bid Date:</u>	2/1/2018	<u>Mandatory Pre Bid Conference:</u>	
<u>Invitation #:</u>		<u>Commence Date:</u>	3/1/2018
<u>Structures:</u>	4	<u>Completion Date:</u>	3/16/2018
<u>Single Trade Project:</u>		<u>Site Area:</u>	
<u>Floors:</u>		<u>LEED Certification Intent:</u>	
<u>Parent Project ID:</u>		<u>Units:</u>	
<u>Parking Spaces:</u>			

Project Participants

Company Role	Company Name	Contact Name	Address	Phone	Email	Fax
Owner	Newark Valley Central School District		68 Wilson Creek Rd. , Newark Valley, NY 13811	(607) 642-3221		
Architect	Keystone Associates Architects Engineers & Surveyors LLC	Sharon Ostrom	58 Exchange St. , Binghamton, NY 13901	(607) 722-1100	sostrom@keyscomp.com	(607) 722-2515

Bidders

Company Name	Contact Name	Added Date	Address	Phone	Email	Bidding Role	Bid Rank	Bid Value	Fax Number
Louis N. Picciano & Son, Inc	Tom Brightsen	1/25/2018	320North Jensen Road , Vestal, NY 13850	(607) 729-1111	tbrightsen@lnpsi.com	Prospective Bidder - General Contractor			(607) 797-6666
Streeter Associates, Inc.	Robert Stanton	1/25/2018	101 East Woodlawn Ave. P O Box 118, Elmira, NY 14902	(607) 734-4151	rstanton@streeterassociates.com	Prospective Bidder - General Contractor			(607) 732-2952
Kimble Inc.	Stephanie Brenzo	1/25/2018	1004 Sullivan St. , Elmira, NY 14901	(607) 734-4123	brenzos@kimbleinc.com	Prospective Bidder - General Contractor			(607) 734-4199
Blanding Electric Inc.	Matthew Labosky	1/25/2018	429 Commerce Road , Vestal, NY 13850	(607) 729-3545	mlabosky@blandingelectric.com	Prospective Bidder - General Contractor			(607) 729-0700
J & K Plumbing & Heating Co. Inc.	Allyn Jones	1/25/2018	24 Thorp St. , Binghamton, NY 13905	(607) 772-1666	allyn.jones@jandkplumbing.net	Prospective Bidder - General Contractor			(607) 724-4048
Fahs Construction Group	Lukas Kresge	1/25/2018	2224 Pierce Creek Road , Binghamton, NY 13903	(607) 724-1835	fahsgcestimating@fahsconstruction.com	Prospective Bidder - General Contractor			(607) 724-7381
Andrew R. Mancini Associates, Inc.	Andrew R. Mancini	1/25/2018	129 Odell Ave. , Endicott, NY 13760	(607) 754-7070	rico@armoggi.com	Prospective Bidder - General Contractor			(607) 786-0410
Matco Electric Corporation	Chris Richard	1/25/2018	3913 Gates Road , Vestal, NY 13850	(607) 729-4921	crichard@matcoelectric.com	Prospective Bidder - General Contractor			(607) 729-0932
Nelcorp Electrical Contracting Corp.	Phil Kasper	1/25/2018	2500 Watson Boulevard , Endicott, NY 13760	(607) 754-8428	pkasper@nelcorpelctrical.com	Prospective Bidder - General Contractor			(607) 785-8783
FE Jones Construction	Rachael Arno	1/25/2018	73 Griswold St. , Binghamton, NY 13902	(607) 348-0045	admin@fejones.com	Prospective Bidder - General Contractor			(607) 348-0050
Piccirilli-Slavik	Georae Slavick	1/25/2018	37 Brandwine	(607) 724-	aslavik3@psv	Prospective			(607) 724-

& Vincent Plumbing & Heating, Inc.	Ill	18	Street , Binghamton, NY 13901	8234	plumbing.com	Bidder - General Contractor			9486
Filtrec Corporation	Fred Clark	1/25/2018	5440 Lockwood Road , Auburn, NY 13021	(315) 253-9266	sales@filtreccorp.com	Prospective Bidder - General Contractor			(315) 253-4458
Bothar Construction, LLC	Pete Jensen	1/25/2018	170 E Service Hwy , Binghamton, NY 13901	(607) 723-5012	pete@botharconst.com	Prospective Bidder - General Contractor			(607) 723-4982
Joseph Baldwin Construction Inc.	Donna Bonney	1/25/2018	689 Silk Rd. , Fulton, NY 13069	(315) 598-3526	dbonney@cnymail.com	Prospective Bidder - General Contractor			(315) 598-3528
W&D Smith Site Development LLC.	Andrew Swift	1/25/2018	1249 Front St Ste 110, Binghamton, NY 13905	(607) 692-4204	ajswift@smithsitedev.com	Prospective Bidder - General Contractor			(607) 692-2705
Huen Electric Inc.	Paul Traver	1/25/2018	6695 Old Collamer Road , East Syracuse, NY 13057	(315) 432-5060		Prospective Bidder - General Contractor			(315) 432-5063
Contour Construction	Steve Ritter	1/25/2018	111 Bevier St. P.O. Box 534, Binghamton, NY 13904	(607) 722-0350	sritter@countourconst.com	Prospective Bidder - General Contractor			(607) 722-3469
Zmk Construction, Inc	Kyle Brame	1/25/2018	3430 Route 434 , Apalachin, NY 13732	(607) 687-0981	kyle.zmk@outlook.com	Prospective Bidder - General Contractor			(607) 687-1485
AJG Associates	Anthony Giammarino	1/25/2018	7 S. Washington St , Binghamton, NY 13903	(607) 203-1387	ajg@ajg-associates.com	Prospective Bidder - General Contractor			(607) 203-1390
LRS Companies	Dan Lapointe	1/25/2018	24 Ross Rd. , Lansing, NY 14882	(607) 533-4889	erika@lrscos.com	Prospective Bidder - General Contractor			(607) 533-7841
Billitier Electric	Stephanie Grzenda	1/25/2018	760 Brooks Ave , Rochester, NY 14619	(585) 224-1111	sgrzenda@billitierelectric.com	Prospective Bidder - General Contractor			(585) 224-1110
Byler Excavating LLC	Leroy Byler	1/25/2018	24 1/2 Spring Forest Ave , Binghamton, NY 13905	(607) 222-7754		Prospective Bidder - General Contractor			

Planholders

Company Name	Contact Name	Address	Phone	Email	Fax
C & K Insulation, Inc.	Edward Staff	179 Dimmock Hill Road , Binghamton, NY 13905	(607) 770-6112	office@ckinsulation.com	(607) 770-6218
Main-Ford General Supply Co	Tanya Colaiaco	366 Lyell Ave , Rochester, NY 14606	(585) 647-2311		
Schuler-Haas Electric	Bob Sivak	701 Azon Road, Suite 203E, Johnson City, NY 13790	(607) 722-3312		(607) 724-5607

Contracts

Classification	Conditions	Bonding	Bid Date	Bids To	Bid Type
General Contractor		Bid:5.00%	2/1/2018	Owner	Open Bidding

History

User	Viewed	First Viewed Date	Currently Tracked?	Date Tracked
Adam Sweet	True	1/29/2018	False	
Bill McIndoo	True	1/24/2018	False	

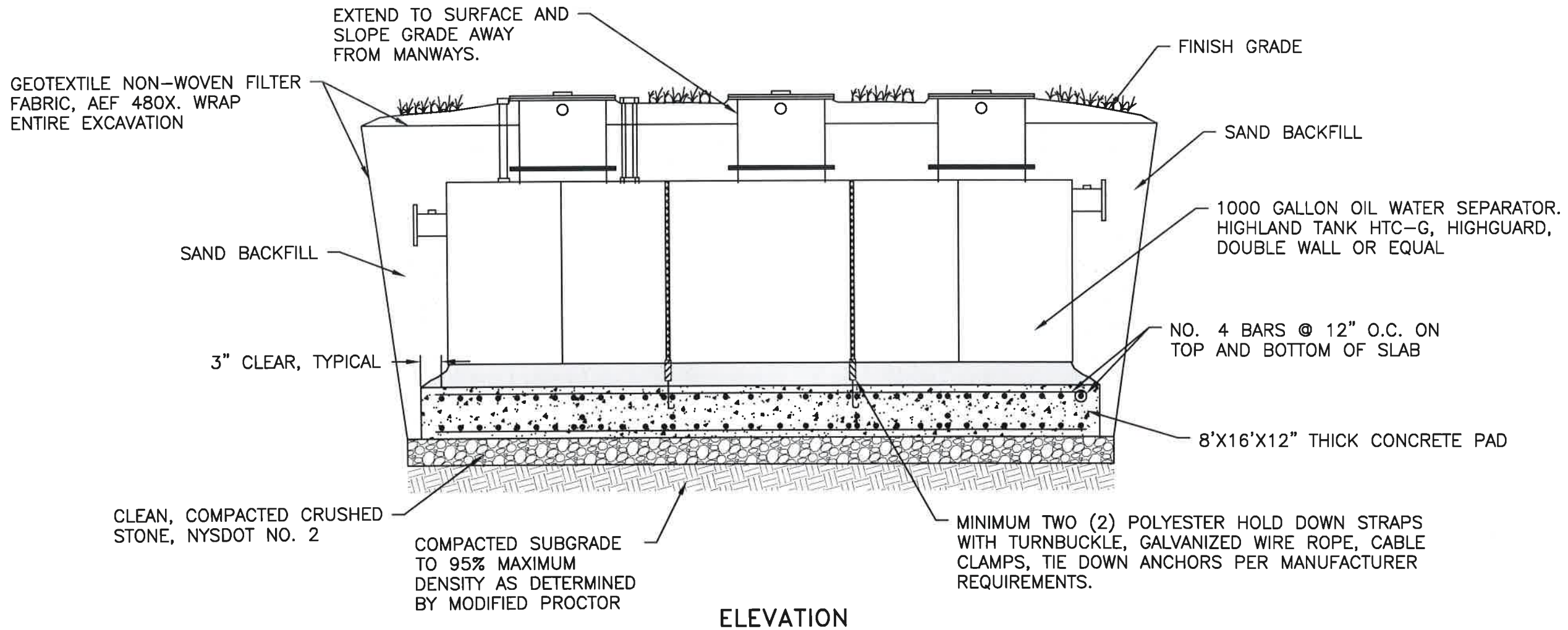
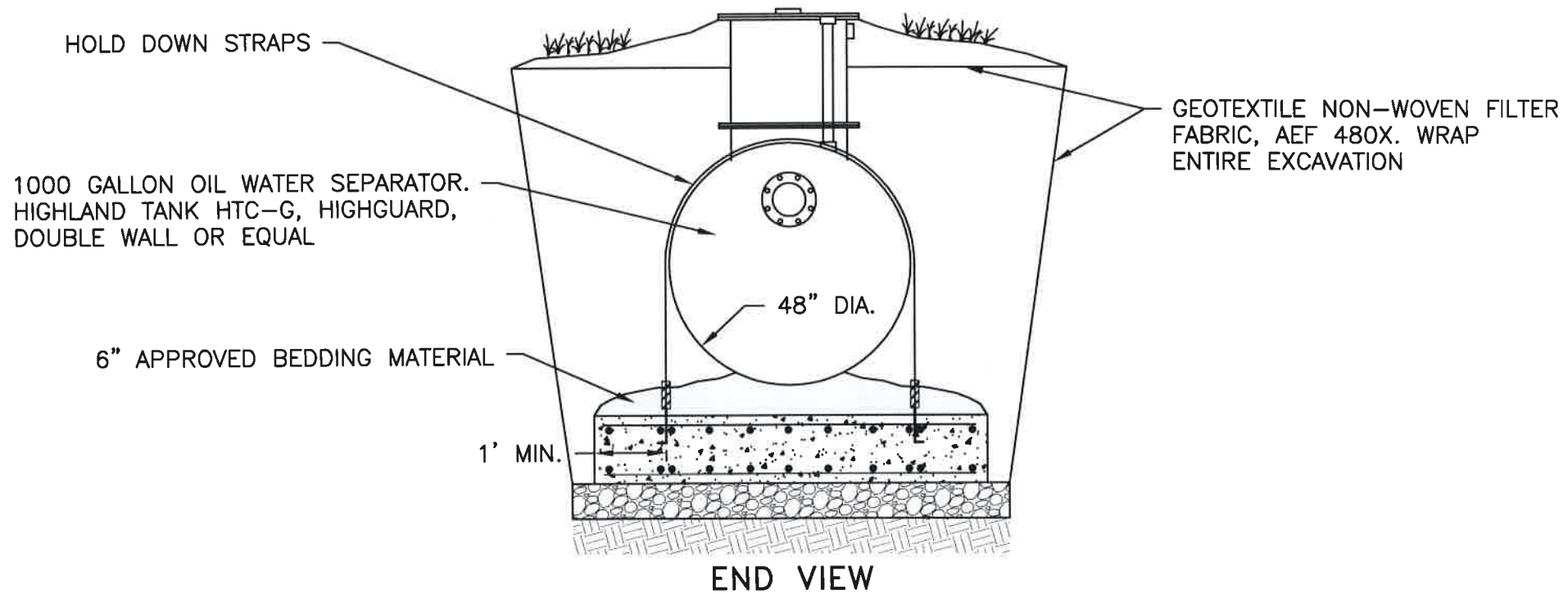

58 Exchange Street
Binghamton, New York 13901
Phone: 607/721.1100
Fax: 607/721.2515
Email: info@keystone.com
www.keystone.com

KEYSTONE ASSOCIATES
ARCHITECTS, ENGINEERS AND SURVEYORS

KeyStone Associates
Architects, Engineers
and Surveyors, LLC

2016 CAPITAL PROJECT-PHASE 2
NEWARK VALLEY CENTRAL
SCHOOL DISTRICT
NEWARK VALLEY
TIOGA COUNTY, NY

OIL WATER SEPARATOR DETAIL

SHEET NO.
AD1-C241

PROJECT NO.
1823.09315.2

DATE
01/23/2018