

Construction of the MassDOT District 3 Administration Building at 365 Plantation Street - Filed Sub Bids

<u>Category:</u>	Government Offices	<u>Project ID #:</u>	1004182905
<u>Street Address:</u>	365 Plantation St. Worcester MA 01605	<u>Confirmed Value</u>	\$14,007,816.00
<u>County:</u>	Worcester	<u>Stage:</u>	BIDDING - SUBBIDS: ASAP
<u>Bid Date:</u>	5/23/2017 , 02:00PM		
<u>Architect:</u>	Helene Karl Architects, Inc.		
<u>Documents Available:</u>	Plans, Specs, Addenda available in Insight		Plans available from Massachusetts Department of Transportation - Highway Division (DOT)
<u>Last Update:</u>	5/18/2017		New Bid date is 05/23/2017

Notes

Scope

Site work and new construction of a municipal facility in Worcester, Massachusetts. Completed plans call for the construction of a municipal facility; and for site work for a municipal facility. Location: WORCESTER Project Type: DCAMM Construction of the MassDOT District 3 Administration Building at 365 Plantation Street. FILED SUB-BIDS: 100.5 ELECTRICAL WORK Project Value: \$7,543,536.00 Construction of the MassDOT District 3 Administration Building at 365 Plantation Street. FILED SUB-BIDS: 100.6 PLUMBING WORK Project Value: \$771,493.00 Construction of the MassDOT District 3 Administration Building at 365 Plantation Street. FILED SUB-BIDS: 100.61 HVAC WORK Project Value: \$2,983,298.00 Construction of the MassDOT District 3 Administration Building at 365 Plantation Street. FILED SUB-BIDS: 100.611 FIRE SUPPRESSION Project Value: \$342,564.00 Construction of the MassDOT District 3 Administration Building at 365 Plantation Street. FILED SUB-BIDS: 100.7 ROOFING AND FLASHING WORK Project Value: \$601,127.00 Construction of the MassDOT District 3 Administration Building at 365 Plantation Street. FILED SUB-BIDS: 100.71 MASONRY WORK Project Value: \$1,080,294.00 Construction of the MassDOT District 3 Administration Building at 365 Plantation Street. FILED SUB-BIDS: 100.711 WATERPROOFING, DAMPROOFING & CAULKING Project Value: \$436,491.00 Construction of the MassDOT District 3 Administration Building at 365 Plantation Street. FILED SUB-BIDS: 100.74 METAL WINDOWS WORK Project Value: \$2,356,790.00 Construction of the MassDOT District 3 Administration Building at 365 Plantation Street. FILED SUB-BIDS: 100.75 PAINTING Project Value: \$276,913.00 Construction of the MassDOT District 3 Administration Building at 365 Plantation Street. FILED SUB-BIDS: 100.76 TILES Project Value: \$386,151.00 Construction of the MassDOT District 3 Administration Building at 365 Plantation Street. FILED SUB-BIDS: 100.77 RESILIENT FLOORING Project Value: \$64,276.00 Construction of the MassDOT District 3 Administration Building at 365 Plantation Street. FILED SUB-BIDS: 100.78 MISCELLANEOUS AND ORNAMENTAL IRON WORK Project Value: \$532,019.00 Construction of the MassDOT District 3 Administration Building at 365 Plantation Street. FILED SUB-BIDS: 100.79 ACOUSTICAL TILES CEILING Project Value: \$376,742.00 Construction of the MassDOT District 3 Administration Building at 365 Plantation Street. FILED SUB-BIDS: 100.8 ELEVATORS Project Value: \$223,740.00 Total Sum Value = \$17,975,434 MassDOT - Construction of the MassDOT District 3 Administration Building at 365 Plantation Street - Filed Sub Bids Bid result: FILED SUB-BIDS: 100.5 ELECTRICAL WORK : WAYNE J GRIFFIN ELECTRIC INC : \$4,499,000.00 FILED SUB-BIDS: 100.6 PLUMBING WORK : GRASSESCHI PLUMBING & HEATING INC : \$628,000.00 FILED SUB-BIDS: 100.61 HVAC WORK : KMD MECHANICAL CORP : \$2,157,000.00 FILED SUB-BIDS: 100.611 FIRE SUPPRESSION : COGSWELL SPRINKLER CO, INC : \$295,409.00 FILED SUB-BIDS: 100.7 ROOFING AND FLASHING WORK : GREENWOOD INDUSTRIES INC : \$493,000.00 FILED SUB-BIDS: 100.71 MASONRY WORK : COSTA BROTHERS MASONRY INC : \$1,150,000.00 FILED SUB-BIDS: 100.711 WATERPROOFING, DAMPROOFING & CAULKING : P. J. SPILLANE COMPANY : \$387,000.00 FILED SUB-BIDS: 100.74 METAL WINDOWS WORK : A & A WINDOW PRODUCTS INC : \$2,438,000.00 FILED SUB-BIDS: 100.75 PAINTING : JOHN W EGAN COMPANY INC : \$147,485.00 FILED SUB-BIDS: 100.76 TILES : WEST FLOOR COVERING INC : \$571,243.00 FILED SUB-BIDS: 100.77 RESILIENT FLOORING : CAPITAL CARPET & FLOORING SPEC., INC. : \$105,898.00 FILED SUB-BIDS: 100.78 MISCELLANEOUS AND ORNAMENTAL IRON WORK : THE BERLIN STEEL CONST CO & SUBSID : \$789,000.00 FILED SUB-BIDS: 100.79 ACOUSTICAL TILES CEILING : K & K ACOUSTICAL CEILINGS INC : \$309,500.00 Apparent Bids for Proposal 606308-99594-100_73 : ALUMINUM & GLASS CONCEPTS INC : \$37,281.00

Notes

Filed Sub-Bid: 05/09/2017 02:00PM Bid date changed from 04/11/2017. Rebid from December 01, 2016. Bid Date: 05/23/2017 02:00PM Bid Date extended to 05/23/2017. Per Addendum 1, the opening of file sub-bids has been postponed to May 9, 2017 at 2:00 PM. Electronic proposals will be received through the internet forthwith after the bid submission deadline. No paper copies of bids will be accepted. All Bidders must have a valid Digital ID issued by MassDOT in order to bid on projects. Bidders need to apply for a Digital ID at least 14 days prior to a scheduled bid opening date. Development include(s): Site Work, New Construction

Details

[Division 2]: Clearing, Dewatering, Earthwork, Grading, Slope Protection & Erosion Control, Tunneling, Paving & Surfacing, Water Systems, Wells, Sewerage & Drainage, Irrigation, Fences & Gates, Landscaping. [Division 3]: Concrete Formwork, Concrete Reinforcement, Structural Concrete. [Division 4]: Clay Unit Masonry, Concrete Unit Masonry, Stone, Marble, Granite. [Division 5]: Structural Steel, Metal Decking, Cold Formed Metal Framing, Metal Fabrications, Metal Stairs, Metal Railings, Ornamental Metals. [Division 6]: Rough Carpentry. Finish Carpentry. Architectural Woodwork. Plastic

Fabrications. [Division 7]: Waterproofing, Dampproofing, Insulation, Firestopping, Manufactured Roofing & Siding, Membrane Roofing, Skylights. [Division 8]: Metal Doors, Wood Doors, Sectional Overhead Doors, Entrances & Storefronts, Metal Windows, Hardware, Glass & Glazing, Curtain Walls. [Division 9]: Ceiling Suspension Systems, Lath & Plaster, Drywall/Gypsum, Tile, Terrazzo, Acoustical Ceilings, Acoustical Walls, Resilient Flooring, Carpet, Painting. [Division 10]: Louvers & Vents, Fireplaces & Stoves, Flagpoles, Interior Signs, Lockers, Partitions, Operable Partitions, Toilet & Bath Accessories. [Division 11]: Food Service Equipment, Laboratory Equipment. [Division 12]: Manufactured Casework, Window Treatment, Rugs & Mats. [Division 13]: Ground Storage Tanks, Underground Storage Tanks, Solar Energy Systems. [Division 14]: Elevators. [Division 15]: Fire Protection Systems, Plumbing Fixtures, Boilers, Packaged A/C Units, Air Handling, Ductwork, Testing & Balancing. [Division 16]: Service/Distribution, Interior Lighting, Emergency Lighting, Standby Power Generator Systems, Alarm & Detection Systems.

Additional Details

<u>Listed On:</u>	10/6/2016	<u>Floor Area:</u>	
<u>Contract Type:</u>		<u>Work Type:</u>	New
<u>Stage Comments 1:</u>		<u>Floors Below Grade:</u>	
<u>Stage Comments 2:</u>		<u>Owner Type:</u>	City
<u>Bid Date:</u>	5/23/2017	<u>Mandatory Pre Bid Conference:</u>	
<u>Invitation #:</u>	606308	<u>Commence Date:</u>	8/7/2017
<u>Structures:</u>	2	<u>Completion Date:</u>	3/19/2019
<u>Single Trade Project:</u>		<u>Site Area:</u>	
<u>Floors:</u>		<u>LEED Certification Intent:</u>	
<u>Parent Project ID:</u>	1004182871	<u>Units:</u>	
<u>Parking Spaces:</u>			

Project Participants

Company Role	Company Name	Contact Name	Address	Phone	Email	Fax
Architect	Helene Karl Architects, Inc.		61 Skyfields Dr. , Groton, MA 01450	(978) 449-0470		(978) 449-0469
Consultant	John J. Murphy, Jr. Electrical Construction & Engineering Inc.		379 Liberty St. , Rockland, MA 02370	(781) 792-0059		(781) 792-0061
HVAC Engineer	Seaman Engineering Corp.		30 Faith Ave. , Auburn, MA 01501	(508) 832-3535		(508) 832-3393
Landscape Architect	RDLA		179 Green Street , Boston, MA 02130	(617) 524-6265	info@raydunetz.com	(617) 522-5029
Structural Engineer	Symmes Maini & McKee Associates (SMMA)		1000 Massachusetts Ave. , Cambridge, MA 02138	(617) 547-5400		(617) 354-5758
Owner	Massachusetts Department of Transportation (massDOT) - Highway Division - District 3	Ed Libsch	403 Belmont St. , Worcester, MA 01604	(857) 368-9672		(508) 799-9763
Owner	Massachusetts Department of Transportation - Highway Division (DOT)	Frank Kucharski	10 Park Plz. Suite 6261, Boston, MA 02116	(857) 368-9520	frank.kucharski@state.ma.us	(617) 973-8040

Bidders

Company Name	Added Date	Address	Phone	Email	Bidding Role	Bid Rank	Bid Value	Fax Number
Wayne J. Griffin Electric, Inc.	5/13/2017	116 Hopping Brook Rd , Holliston, MA 01746	(508) 429-8830	imorton@wjgei.com	Apparent Low - Electrical Contractor	1	\$4,499,000.00	(508) 429-7825
Grasseschi Plumbing & Heating Inc.	5/13/2017	1299 Grafton St , Worcester, MA 01604	(508) 753-3028	mdupre@grasseschi.com	Apparent Low - Plumbing Contractor	1	\$628,000.00	(508) 799-4953
A & A Window Products, Inc.	5/13/2017	15 Joseph Street , Malden, MA 02148	(781) 322-9282	sales@aaawindowproducts.com	Apparent Low - Subcontractor	8	\$2,438,000.00	(781) 321-0833
Aluminum & Glass Concepts Inc	5/13/2017	210 Andover St Ste 25 P.O. Box 279, Wilmington, MA 01887	(978) 658-3591	atryder@aluminumandglass.com	Apparent Low - Subcontractor	1	\$37,281.00	(978) 657-5819

PJ Spillane Company Inc	5/13/2017	97 Tileston St , Everett, MA 02149	(617) 389-6200	arossetti@pjspillane.com	Apparent Low - Waterproofing	1	\$387,000.00	(617) 389-4138
Cogswell Sprinkler Company	5/13/2017	22 Canterbury St. , Worcester, MA 01610	(508) 753-0015	john@cogswellsprinkler.com	Apparent Low - Fire Protection	1	\$295,409.00	(508) 753-5629
Capital Carpet & Flooring Specialists Inc.	5/13/2017	12 Walnut Hill Park P.O. Box 2633, Woburn, MA 01801	(781) 935-9430	maureenc@capitalcarpetonline.com	Apparent Low - Subcontractor	2	\$105,898.00	(781) 935-5737
Costa Brothers Masonry, Inc	5/12/2017	2 Lambeth Park Dr. , Fairhaven, MA 02719	(508) 991-7634	cbm@costamaso-nrv.com	Apparent Low - Masonry	1	\$1,150,000.00	(508) 991-7635
West Floor Covering, Inc.	5/13/2017	42 Winter St. Suite 11, Pembroke, MA 02359	(781) 826-9022	info@westfloorcovering.com	Apparent Low - Subcontractor	6	\$571,243.00	(781) 826-7073
Greenwood Industries Inc.	5/13/2017	640 Lincoln St , Worcester, MA 01605	(508) 865-4040		Apparent Low - Subcontractor	5	\$493,000.00	(508) 865-1123
The Berlin Steel Construction Company	5/13/2017	5 Industrial Park Road West , Oxford, MA 01540	(508) 987-7924	trussell@berlinsteel.com	Apparent Low - Subcontractor	7	\$789,000.00	(508) 987-8748
Kmd Mechanical Corporation	5/13/2017	310 Southwest Cutoff , Worcester, MA 01604	(508) 795-1828		Apparent Low - HVAC Contractor	1	\$2,157,000.00	
John W Egan Co. Inc.	5/13/2017	PO Box 600070 , Newtonville, MA 02460	(617) 244-6390	mcote@johnwegan.com	Apparent Low - Subcontractor	3	\$147,485.00	(617) 244-6108
CTA Construction Co. Inc.	4/5/2017	400 Totten Pond Rd Suite 2nd Floor, Waltham, MA 02451	(781) 786-6600	info@ctaconstruction.com	Bidder - Subcontractor			(781) 786-6670
K&K Acoustical Ceilings, Inc.	5/13/2017	1881 Main St Ste. 7, Tewksbury, MA 01876	(978) 851-8844		Apparent Low - Subcontractor	4	\$309,500.00	(978) 851-8291

Planholders

Company Name	Address	Phone	Email	Fax
Chapman Waterproofing Company	395 Columbia Rd PO Box 255300, Boston, MA 02125	(617) 288-3000	info@chapmanwaterproofing.com	(617) 288-3005
WES Construction Corp.	650 Industrial Dr. , Halifax, MA 02338	(781) 294-1080	kvogel@wesconstructioncorp.com	(781) 294-4597
Annese Electrical Services	280 Libbey Industrial Pkwy. , Weymouth, MA 02189	(781) 337-6462		(781) 337-6559
N.B. Kenney	68 Barnum Road , Devens, MA 01434	(978) 849-5200	skenny@nbkenney.com	(978) 849-5298
Marmelo Bros	13 Ventura Dr , North Dartmouth, MA 02747	(508) 995-6582	sandy@marmeloconstruction.com	(508) 995-6926
Rockwell Roofing Inc.	44 Pond St , Leominster, MA 01453	(978) 537-7825	jpicaard@rockwellroofing.com	(978) 537-4132
Boston Building & Bridge Corp.	1094 Bluehill Ave. , Milton, MA 02186	(617) 333-0342	info@bbbcorp.com	(617) 333-6895
William F. Lynch Co., Inc.	50 Millbrook Street , Worcester, MA 01606	(508) 756-5705	mlynch@wflynchinc.com	(508) 756-0089
Charles M. Moran Plumbing & Heating, Inc.	54 Allen St. , Clinton, MA 01510	(978) 368-0355		(978) 368-0890
Central Ceilings	36 Norfolk Ave , South Easton, MA 02375	(508) 238-6985	bid_invites@centralceilings.com	(508) 238-2191
John F. Shea Co. Inc.	41 Hollingsworth St. P.O. Box 365, Mattapan, MA 02126	(617) 298-0356	csears@johnfshea.com	(617) 296-8859
J.D. Rivet & Co. Inc.	1635 Page Blvd P.O. Box 51068, Springfield, MA 01104	(413) 543-5660	info@rivetroofing.com	(413) 543-3373
Capeway Roofing Systems	664 Sandford Road , Westport, MA 02790	(508) 674-0800	krybicki@capewayroofing.com	(508) 678-2670
Joseph Cohn & Son, Inc.	50 Devine Street , North Haven, CT 06473	(203) 772-2420		(203) 230-0340
R&R Window Contractors, Inc.	One Arthur St. , Easthampton, MA 01027	(413) 527-7500	tsmith@rrwindow.com	(413) 527-0289
Fontaine Brothers, Inc.	510 Cottage St. , Springfield, MA 01104	(413) 781-2020	careers@fontainebros.com	(413) 781-1881
Folan Waterproofing &	795 Washington St. . South	(508) 238-	office@folanwaterproofing.com	(508) 238-

Construction Co.	Easton, MA 02375	6550		9425
Adams Plumbing & Heating Inc.	43 Printworks Drive P.O. Box 126, Adams, MA 01220	(413) 743-2308	info@adamsphinc.com	(413) 743-7350
Carlyle Engineering, Inc	132 Brookside Ave , Boston, MA 02130	(617) 522-6650	carlyle@carlyle.com	(617) 522-9021
Sullivan & Narey Construction Co	214 Maple St , Holyoke, MA 01040	(413) 532-6974		(413) 532-0656
Chabot & Burnett Construction Co Inc	36 Ramah Circle North Agawam , Agawam, MA 01001	(413) 567-7681	zcolson@chabotandburnett.com	(413) 786-1354
Lizotte Glass Inc.	390 Race St. , Holyoke, MA 01040	(413) 532-2737		(413) 532-0069
Chandler Architectural Products	255 Interstate Drive , West Springfield, MA 01089	(413) 733-1111		(413) 737-6101
Rustic Fire Protection Inc	320 West Main Street P.O. Box 1210, Norton, MA 02766	(508) 431-9938	cdubuc@rusticfireprotection.com	(508) 431-9986
SMJ Metal, Inc	36 Smith St , Northampton, MA 01060	(413) 586-3535	jpayne@ralphsblacksmith.com	(413) 587-0350
M Frank Higgins & Co. Inc.	780 N. Mountain Rd , Newington, CT 06111	(860) 953-6826	kcloud@mfhiggins.com	(860) 953-9420
King Painting, Inc.	50 High St., Suite 22, North Andover, MA 01845	(978) 683-7434	cking@kingpaintinginc.com	(978) 683-7198
Bouchard Painting Inc	130 Warner Hill Road , Derry, NH 03038	(603) 434-0773		(603) 425-7545
Greenfield Glass	52 River St. , Greenfield, MA 01301	(413) 774-5277	gglass@greenfieldglass.com	(413) 774-5523
General Mechanical Contractors	29A Sword St. , Auburn, MA 01501	(508) 754-7366	support@generalinc.com	(508) 756-6750
Daniel O'Connell's Sons, Inc. - Western Massachusetts	480 Hampden St. , Holyoke, MA 01040	(413) 534-0243	estimating@oconnells.com	
Commercial Roofing & Contracting	340 Kennedy Dr., P.O. Box 647, Putnam, CT 06260	(860) 928-9199		(860) 928-9244
CJM Services, Inc	50 Kerry Pl P.O. Box 424, Norwood, MA 02062	(781) 440-0000	info@cjm��ervicesinc.com	(781) 440-0046
Feeley McAnespie Inc.	200 Tanner Street , Lowell, MA 01852	(978) 441-2300	imcanesDie@fmiroofino.com	(978) 441-2316
J & J Contractors, Inc.	101 Billerica Ave., Building 5 Ste. 205, North Billerica, MA 01862	(978) 452-9898	info@jjcontractor.com	(978) 452-3796
Armani Restoration	191 Franklin Avenue , Hartford, CT 06114	(860) 296-6811	estimating@armanirestoration.com	(860) 296-1867
Stanley Roofing Co Inc	42 Mitchell Rd , Ipswich, MA 01938	(978) 356-7958	jason@stanleyroof.com	(978) 356-1499
Brennan Interior Contractors	127 Camelot Dr Suite 2, Plymouth, MA 02360	(508) 830-3830	estimating@brennancontractors.com	(508) 830-3833
Pavilion Floors, Inc.	90 Commerce Way , Woburn, MA 01801	(781) 933-8500	info@pavilionfloors.com	(781) 932-8844
Energy Electric Co.	740 Quaker Hwy , Uxbridge, MA 01569	(508) 278-3200	eec@energyelectricne.com	(508) 278-3229
LaPan Mechanical Contractors	3 Bethany Street , Worcester, MA 01604	(508) 793-2164	business@lapanmechanical.com	(508) 793-2193
Bello Painting Co.	585 East St. , Weymouth, MA 02189	(781) 331-5600		(781) 331-5603
Dagle Electrical Construction Corp.	68 Industrial Way , Wilmington, MA 01887	(800) 379-1459	dec@deccorp.com	(781) 937-7678
EDM Construction Inc	125 E. main Street , Merrimac, MA 01860	(978) 346-9898	estimating@edmconstruction.net	(978) 346-9833
W.T. Rich Company	29 Crafts St. Ste. 300, Newton, MA 02458	(617) 467-6010	wtrich@wtrich.com	(617) 467-6011
Kenney Masonry	PO Box 2506 , Amherst, MA 01004	(413) 256-0400	iosh@kenneymasonry.com	(413) 825-5557
Harold Brothers Mechanical	44 Woodrock Rd , Weymouth, MA 02189	(781) 871-2111	info@haroldbros.com	(781) 871-2002
Dandis Contracting Inc	1020 Turnpike Street, Unit 12, Canton, MA 02021	(781) 828-9313	info@dandiscontracting.com	(781) 828-9314
The Cheviot Corporation	55 Fourth Avenue , Needham Hgts, MA 02494	(781) 449-1100	info@cheviotcorp.com	(781) 449-1109
Yankee Sprinkler	612R Plymouth St. Ste 1, East Bridgewater, MA 02333	(508) 378-7212	mpayton@ysc-fire.com	(508) 378-7215
Kapiloff's Glass, Inc.	5 Hoosac St. , Adams, MA 01220	(844) 527-4527	estimating@kapglass.com	(844) 634-5277

Empire Masonry Corporation	231 Norfolk Street, , Walpole, MA 02081	(508) 660-1011	smccormick@empiremasonrycorp.com	(508) 660-1028
Aero Mechanical, Inc.	10 Leah Street , Johnston, RI 02919	(401) 751-8880		(401) 751-7595
Levangie Elec Co Inc	59 Old Webster St. , Hanover, MA 02339	(781) 871-2639		(781) 331-8437
Superior Caulking & Waterproofing Co., Inc	1154 Park Street Suit 1, Palmer, MA 01069	(413) 289-0100	annette@scwi.net	(413) 289-0022
Tim's Fabricators, Inc	87 Putnam St , Fitchburg, MA 01420	(978) 345-0599	jharris@timsfab.com	(978) 348-1635
Coghlin Electrical Contractors	100 Prescott Street , Worcester, MA 01605	(508) 793-0300	kevinhennessy@coghlin.com	(508) 793-0303
L.A.L. Masonry, Inc	3 Bourbon Street, Unit 4, Peabody, MA 01960	(781) 231-1844		(781) 231-1811
Robert W Irvine & Sons	147 Blossom St , Lynn, MA 01902	(781) 581-0464		(781) 581-2860
Wolverine Fire Protection, Co	2170 Commerce Ave. Ste B, Concord, CA 94520	(925) 825-1204	wfpc@wolverinefp.com	(925) 825-1235

Contracts

Classification	Conditions	Bonding	Bid Date	Bids To	Bid Type
General Contractor		Bid:5.00%	5/23/2017	Owner	Open Bidding

History

User	Viewed	First Viewed Date	Currently Tracked?	Date Tracked
Adam Sweet	True	10/19/2016	True	5/2/2017



Ten Park Plaza
 Suite 4160
 Boston, MA 02116
 617-973-7000
 www.mass.gov/massdot

Project Name:
**DISTRICT 3
 ADMINISTRATION
 BUILDING**

MASSDOT Project #606308

Project Location
**365 PLANTATION PARKWAY
 WORCESTER, MA**

Project Architect
HELENE · KARL
 Architects, Inc.
 61 Skyfields Drive, Groton, Massachusetts 01450

Project Consultant
SMMA
 SYMMES MANN & MCKEE ASSOCIATES
 1000 Massachusetts Avenue
 Cambridge, Massachusetts 02138
 (617) 552-5300, (617) 552-8800

Professional Stamp Professional Stamp

Drawn By: RTL
 Checked By: BRW
 HKA Project No.
 Scale:

Original Issue Date

Revisions
 No. Description Date
 BID SET 03/01/17

FUELING STATION CANOPY
 PLANS AND DETAILS

Plan Name:
**Fueling Station Canopy
 Plans and Details**

Drawing Number:
S-502

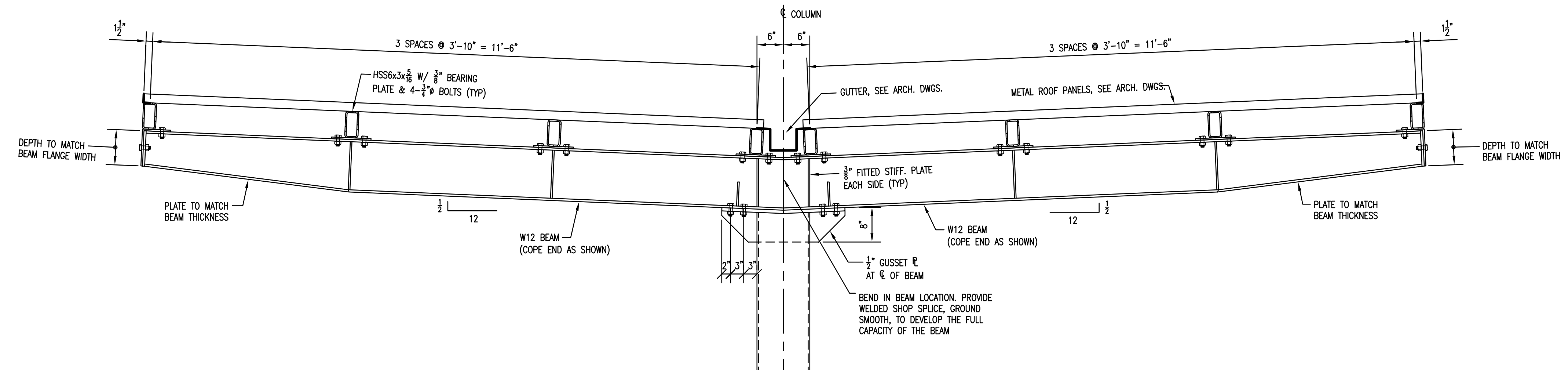
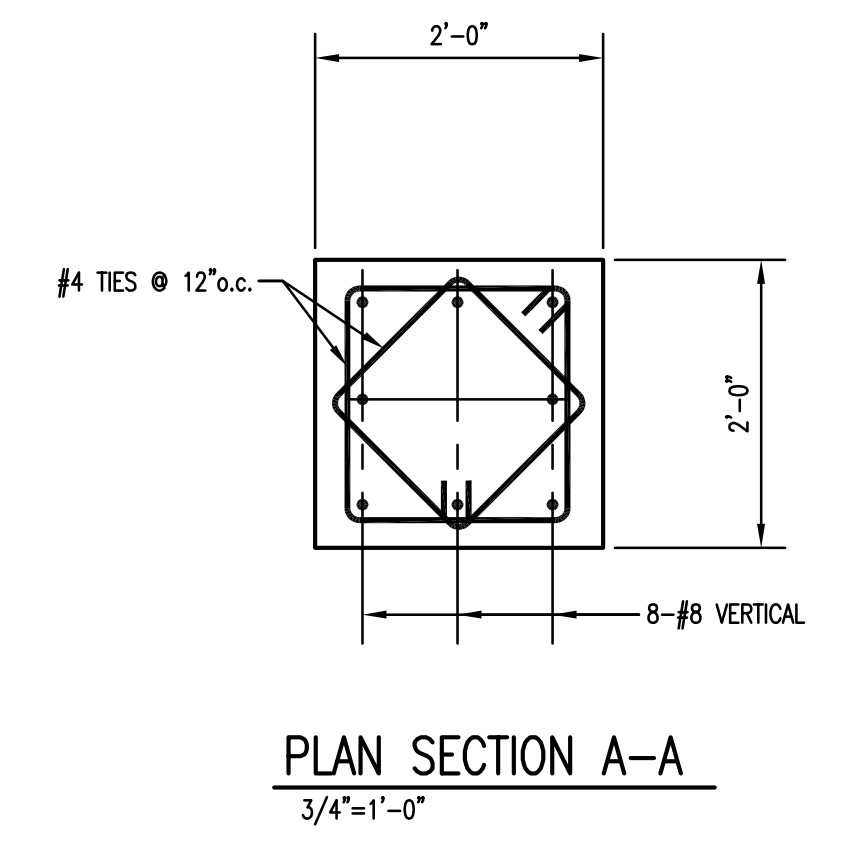
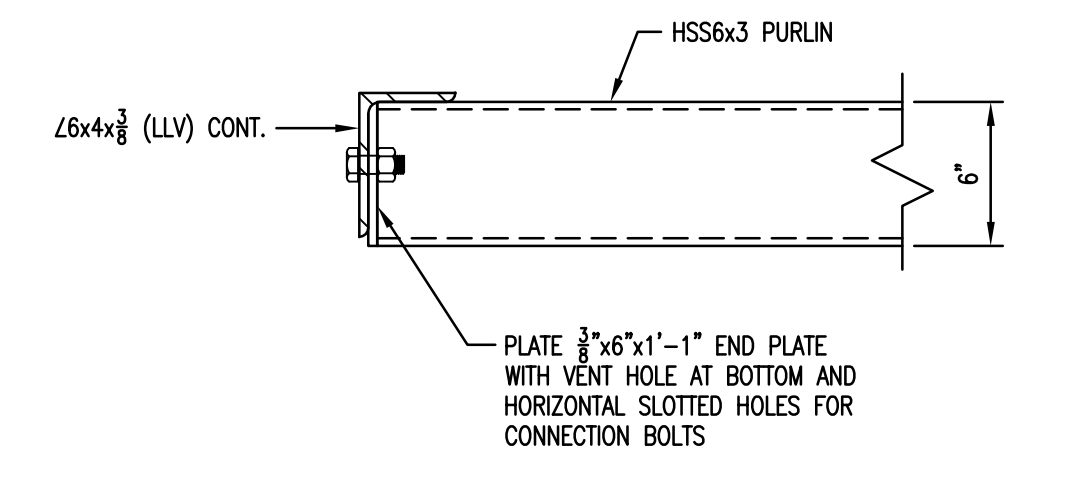
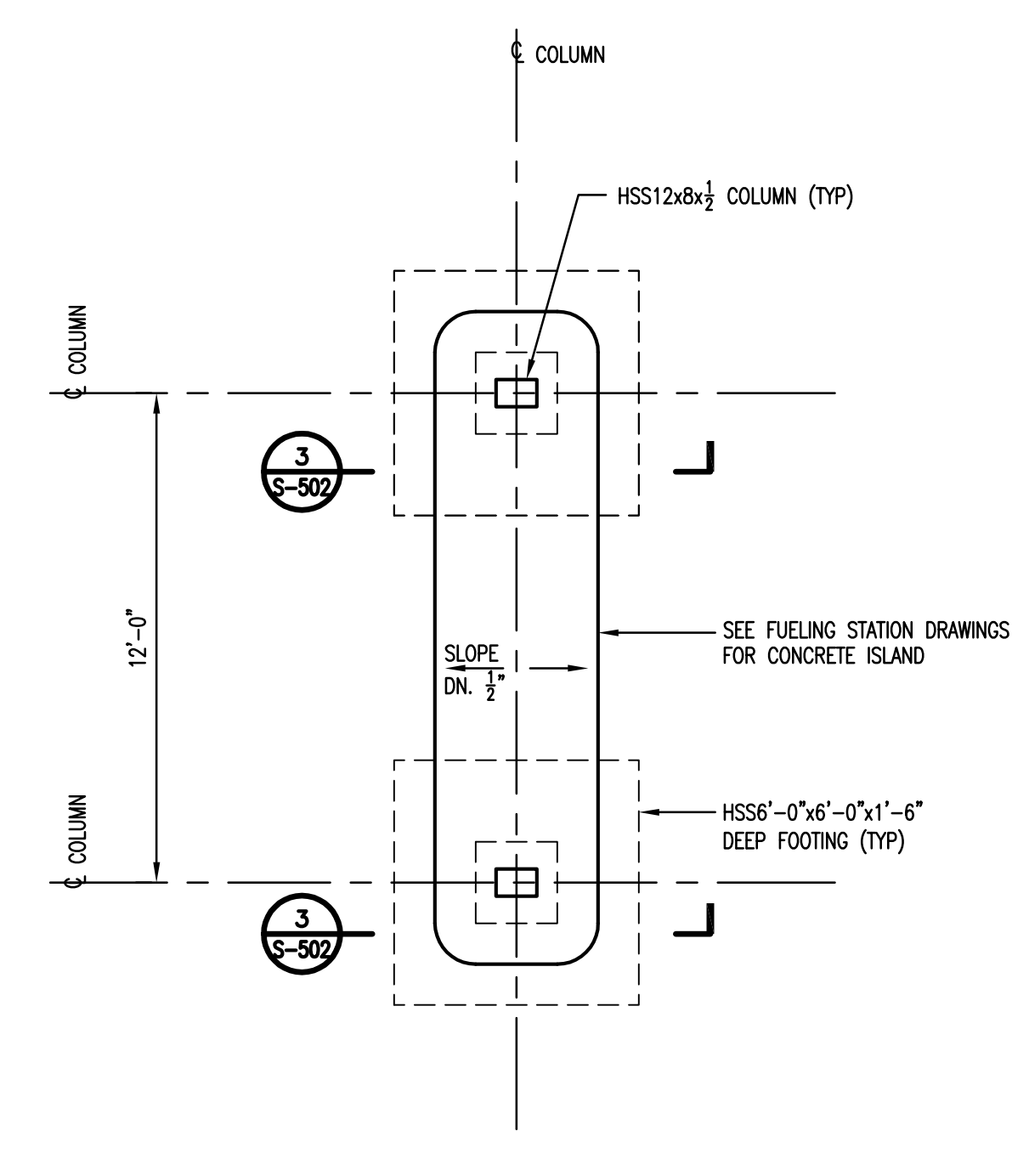
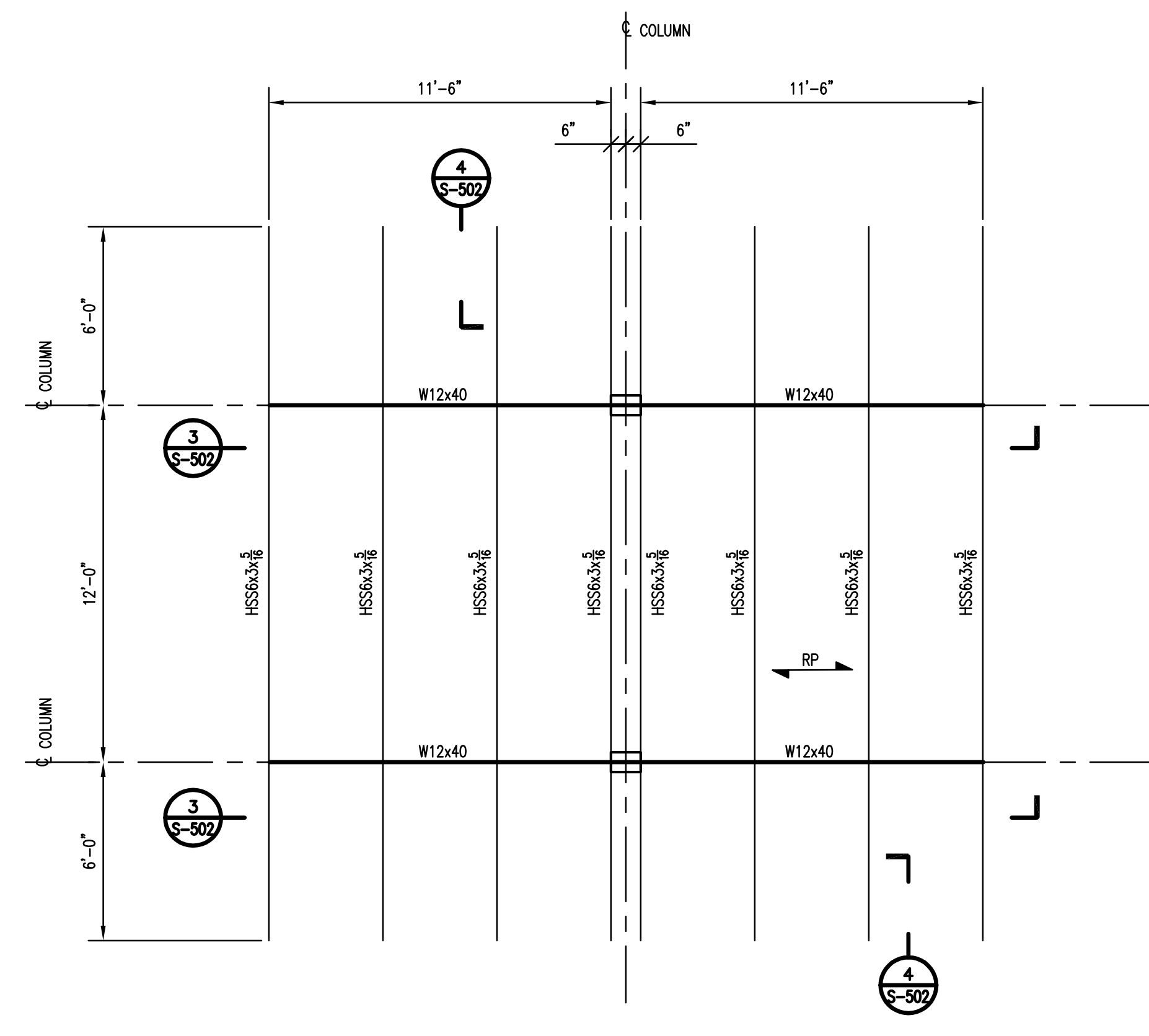

- GENERAL NOTES
- STRUCTURAL STEEL CONNECTION HARDWARE SHALL BE GALVANIZED.
 - CONCRETE: f'_c=4000 PSI
 - DESIGN LOADS: LOADS NOTED ARE UNFACTORED WORKING STRESS LOADS:
 DEAD LOADS:
 PV PANEL ALLOWANCE 6 PSF
 SNOW LOADS:
 60 PSF ACTING ON ENTIRE SPAN
 60 PSF ON ONE SIDE OF COLUMN AND 30 PSF ON THE OTHER.
 WIND LOADS:
 30 PSF ACTING UPWARD OR DOWNWARD ON ONE SIDE OF COLUMN.
 SEISMIC:
 SEE S-001 FOR SEISMIC SITE CRITERIA
 - FOUNDATION DESIGN IS BASED ON A MINIMUM ALLOWABLE BEARING PRESSURE OF 2 TSF.

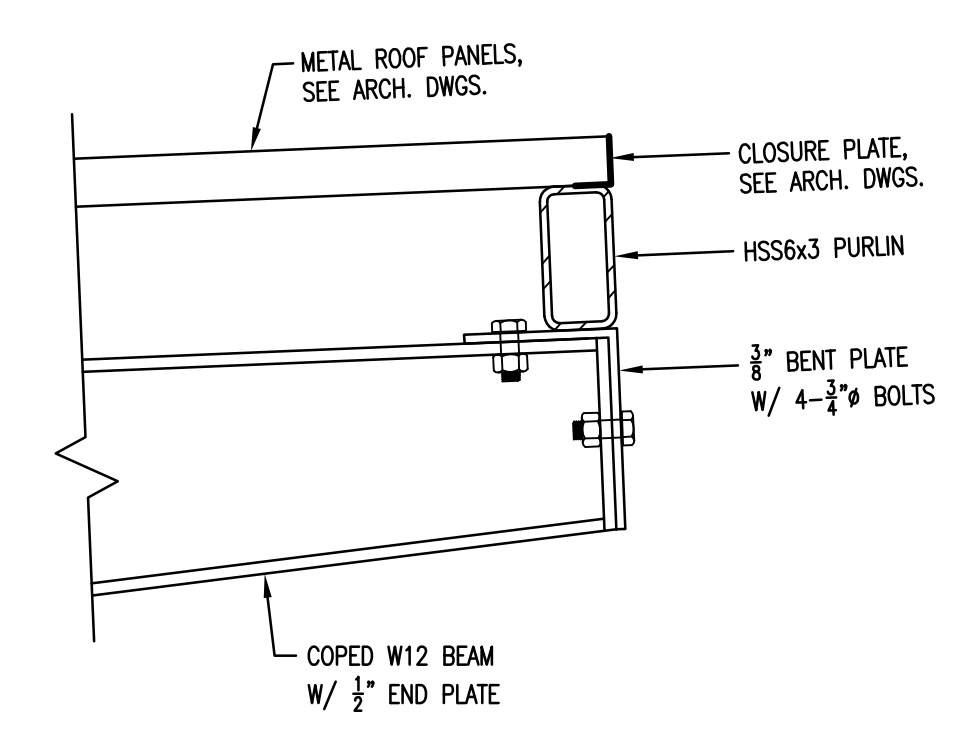
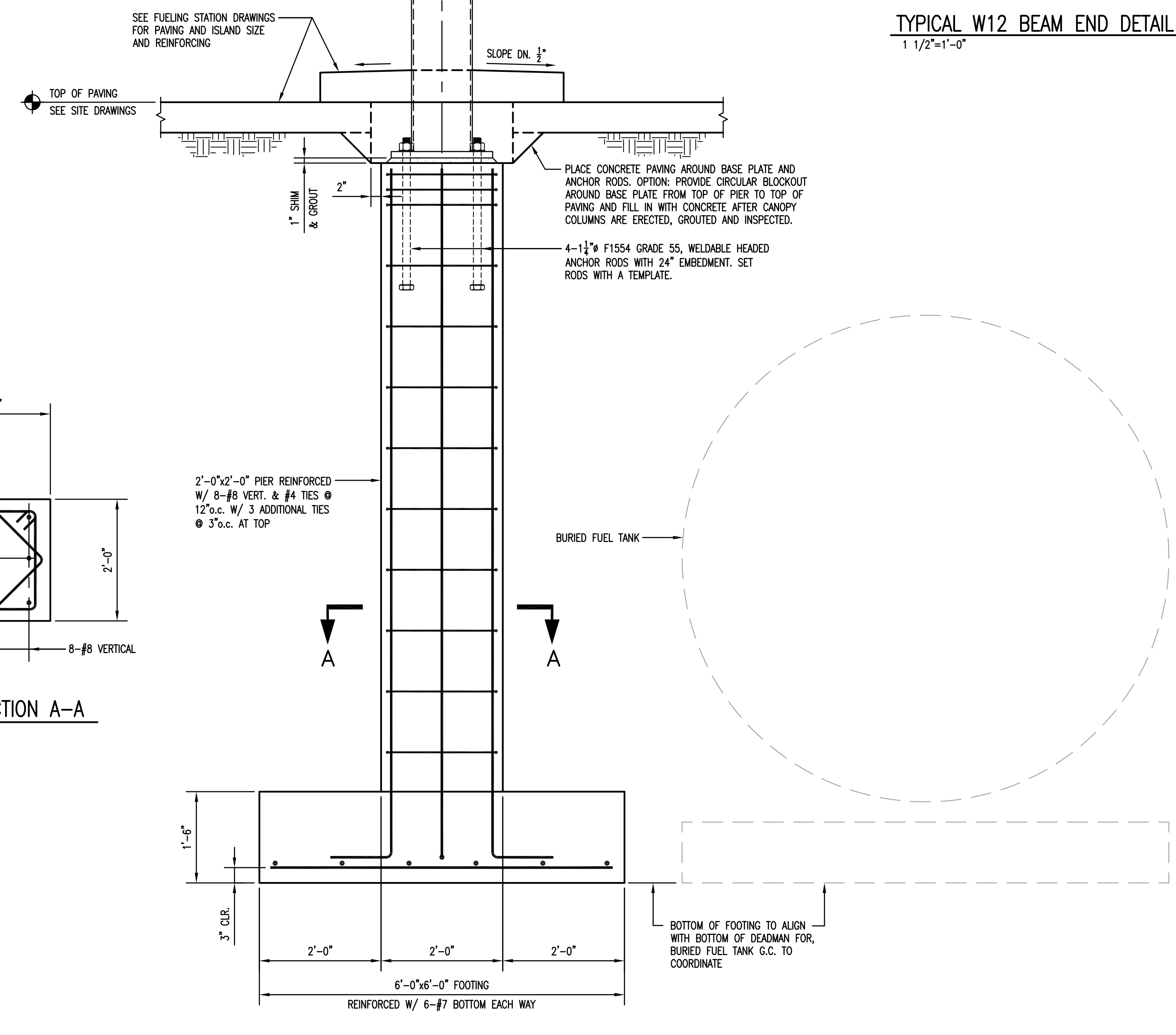

3 FUELING STATION CANOPY SECTION
 3/4"=1'-0"



Ten Park Plaza
Suite 4160
Boston, MA 02116
617-973-7000
www.mass.gov/massdot

Project Name:
DISTRICT 3 ADMINISTRATION BUILDING

MASSDOT Project #606308

Project Location
365 PLANTATION PARKWAY
WORCESTER, MA

Project Architect
HELENE · KARL
 Architects, Inc.
 61 Skyfields Drive, Groton, Massachusetts 01450

Project Consultant
TIGHE & BOND

Professional Stamp Professional Stamp

Drawn By: JMH, LPT, ALP
 Checked By: GMR
 HKA Project No.
 Scale:

Original Issue Date

Revisions No.	Description	Date
BID SET		3/1/17

Plan Name:
FLEET FUELING STATION

Drawing Number:
FS - 001

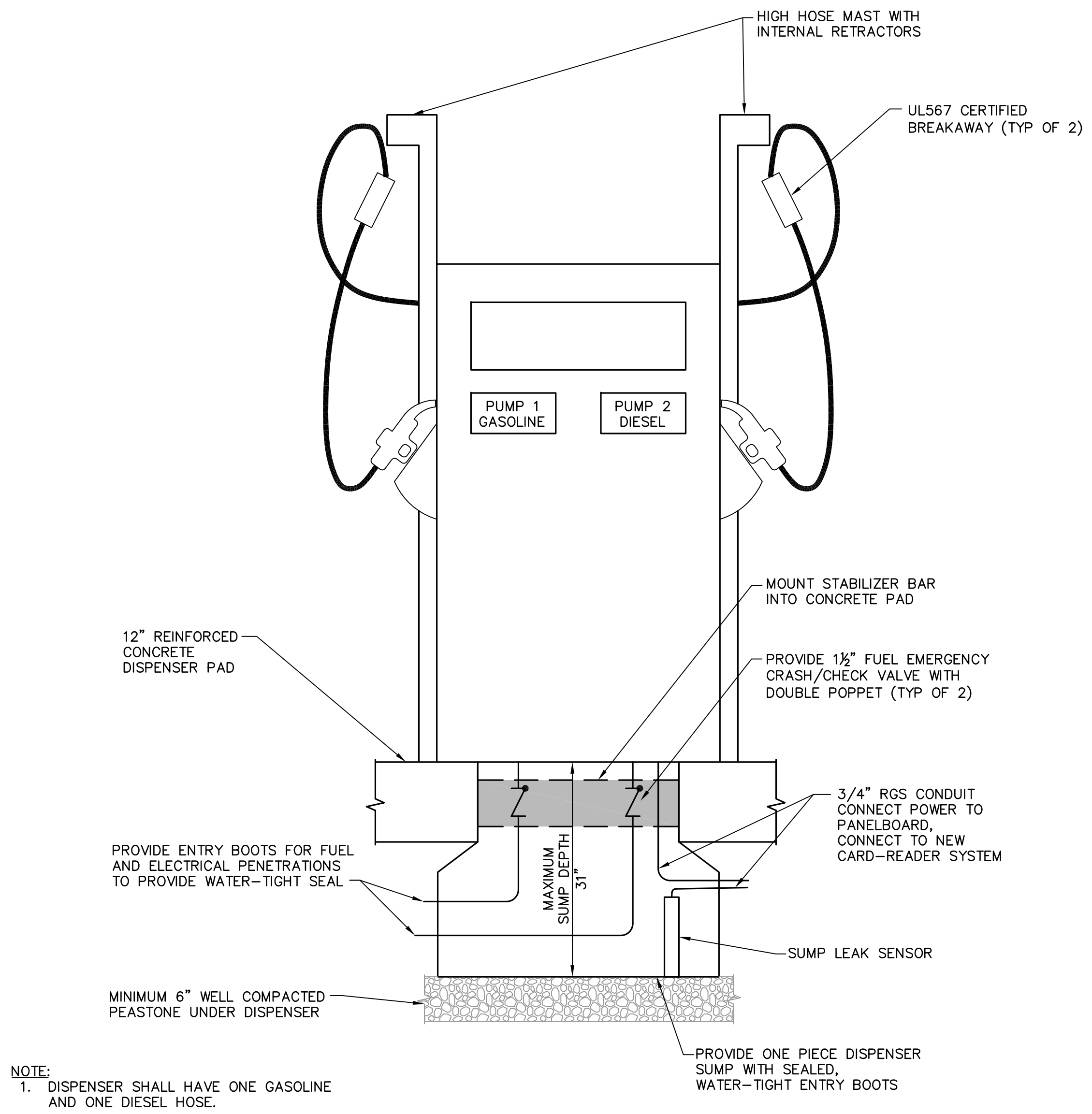

TWIN HOSE FUEL PUMP DETAIL
 NO SCALE

NOTE:
 1. DISPENSER SHALL HAVE ONE GASOLINE AND ONE DIESEL HOSE.

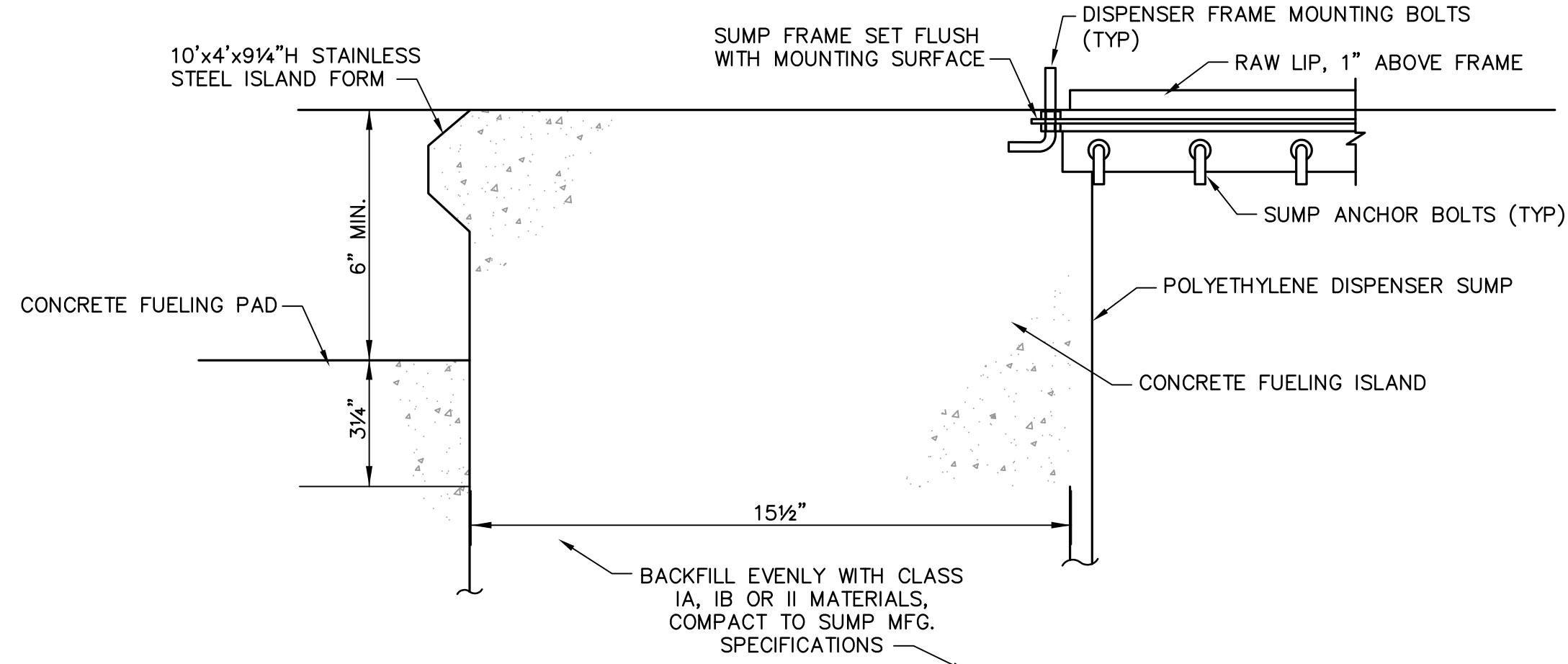

FUEL ISLAND CURB AND SUMP INSTALLATION DETAIL
 NO SCALE

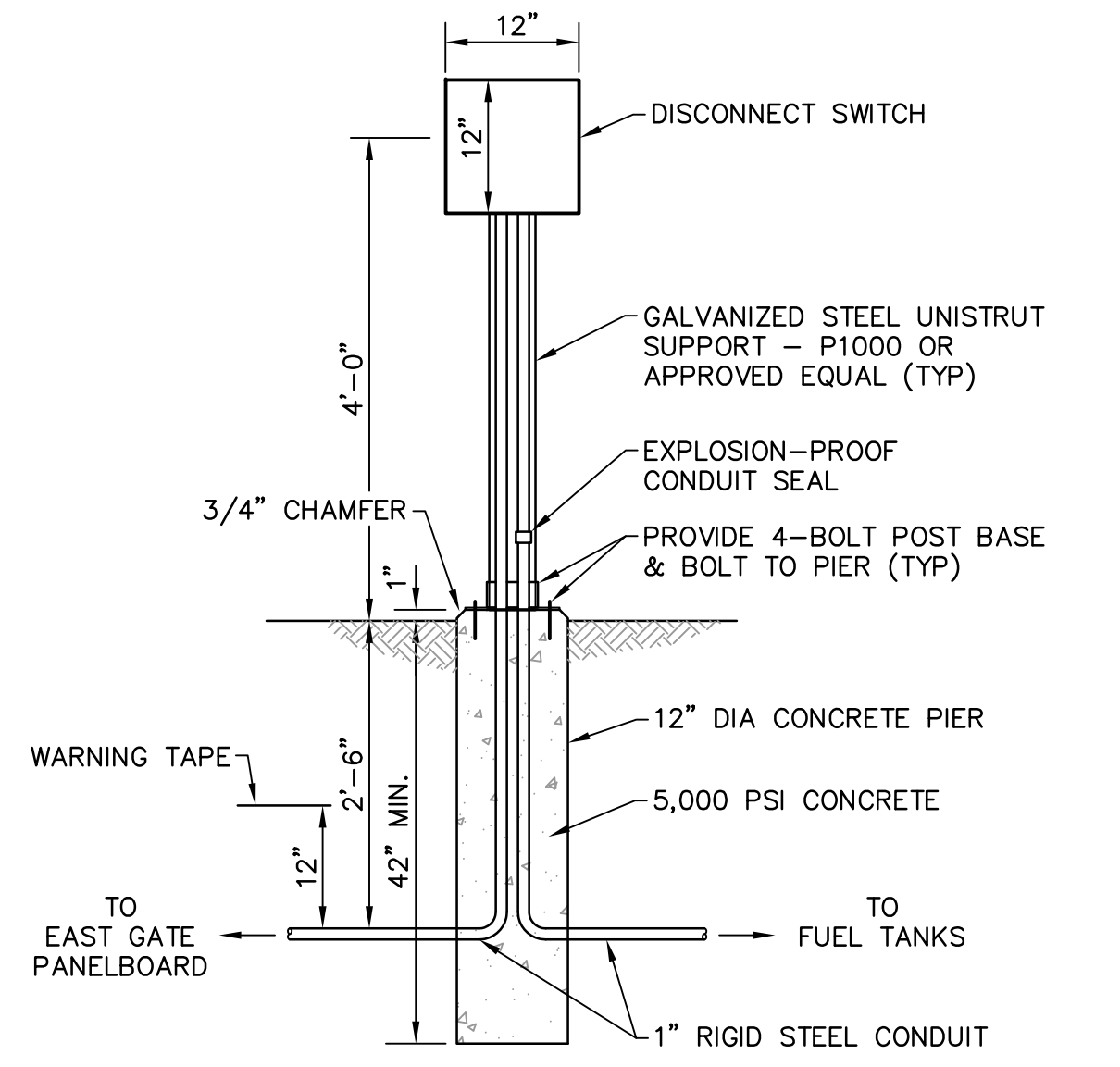

NOTE:
 LABEL THE DISCONNECT SWITCH IN RED LETTERS:
 "FUEL TANK EMERGENCY DISCONNECT"

EMERGENCY DISCONNECT SWITCH INSTALLATION DETAIL
 NO SCALE

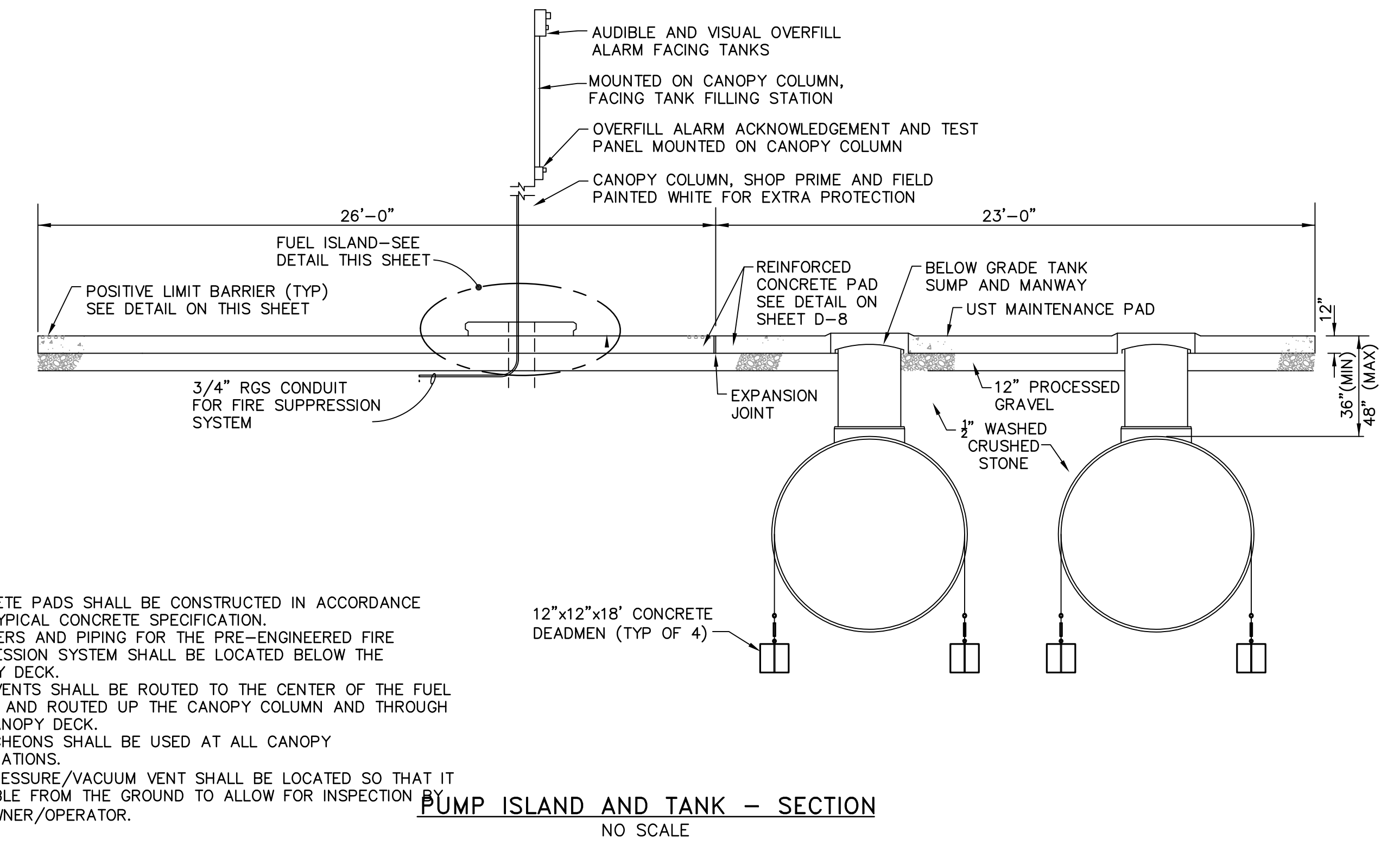

- NOTES:
1. CONCRETE PADS SHALL BE CONSTRUCTED IN ACCORDANCE WITH TYPICAL CONCRETE SPECIFICATION.
 2. CYLINDERS AND PIPING FOR THE PRE-ENGINEERED FIRE SUPPRESSION SYSTEM SHALL BE LOCATED BELOW THE CANOPY DECK.
 3. TANK VENTS SHALL BE ROUTED TO THE CENTER OF THE FUEL ISLAND AND ROUTED UP THE CANOPY COLUMN AND THROUGH THE CANOPY DECK.
 4. ESCUTCHEONS SHALL BE USED AT ALL CANOPY PENETRATIONS.
 5. THE PRESSURE/VACUUM VENT SHALL BE LOCATED SO THAT IT IS VISIBLE FROM THE GROUND TO ALLOW FOR INSPECTION BY THE OWNER/OPERATOR.

PUMP ISLAND AND TANK - SECTION
 NO SCALE

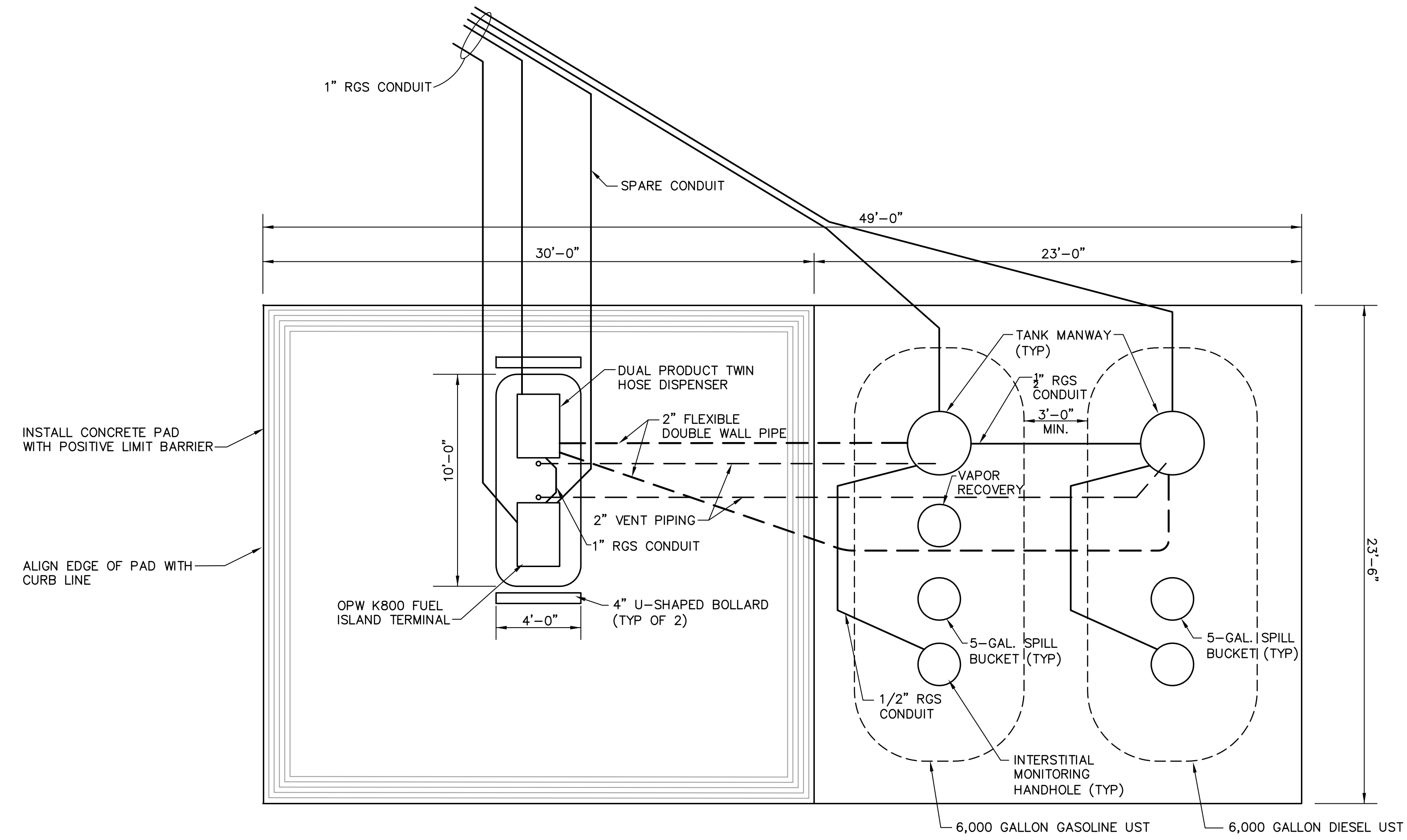

PUMP ISLAND & TANKS - PLAN
 NO SCALE



Ten Park Plaza
Suite 4160
Boston, MA 02116
617-973-7000
www.mass.gov/massdot

Project Name:
DISTRICT 3
ADMINISTRATION
BUILDING

MASSDOT Project #606308

Project Location
365 PLANTATION PARKWAY
WORCESTER, MA

Project Architect
HELENE · KARL
Architects, Inc.
61 Skyfields Drive, Groton, Massachusetts 01450

Project Consultant
TIGHE & BOND

Professional Stamp Professional Stamp

Drawn By: JMH, LPT, ALP
Checked By: GMR
HKA Project No.
Scale:

Original Issue Date

Revisions
No. Description Date
BID SET 3/1/17

Plan Name:
FLEET FUELING STATION

Drawing Number:
FS - 002

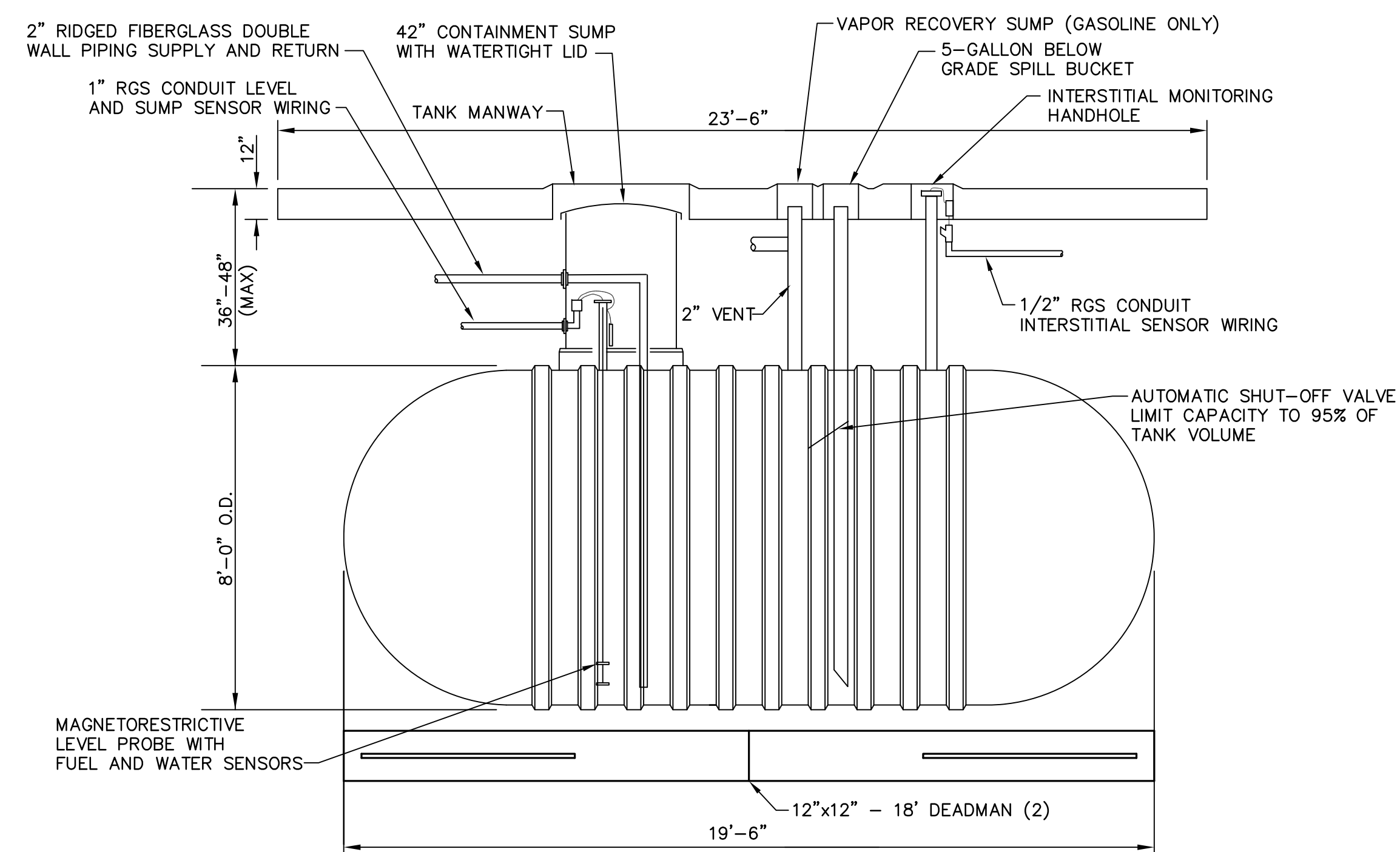

NOTES:
1. THE QUANTITY, LOCATION AND MATERIAL FOR HOLDDOWN STRAPS SHALL BE AS SPECIFIED BY THE TANK MANUFACTURER.

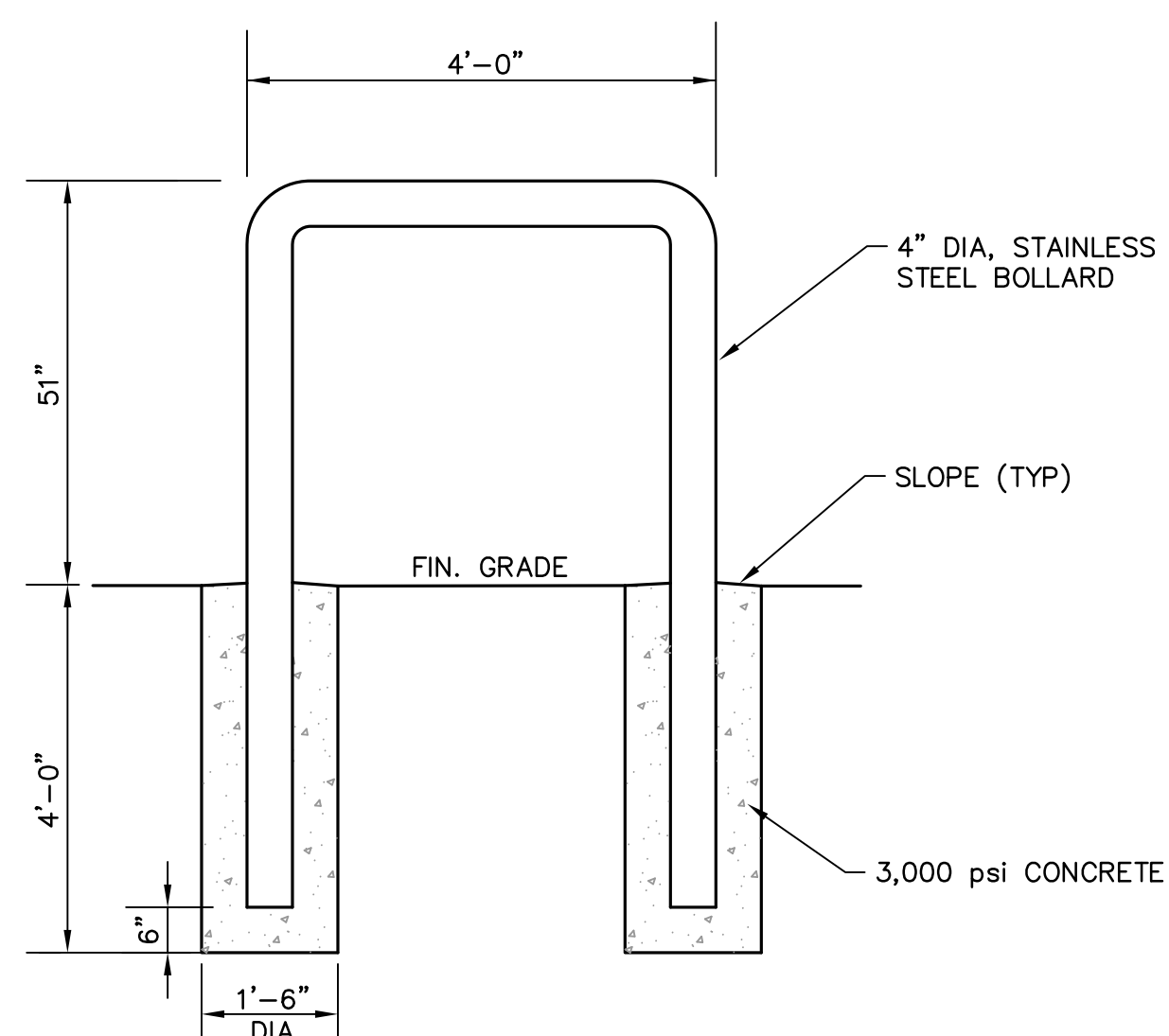

4" DIAMETER U-SHAPED STEEL BOLLARD
NO SCALE

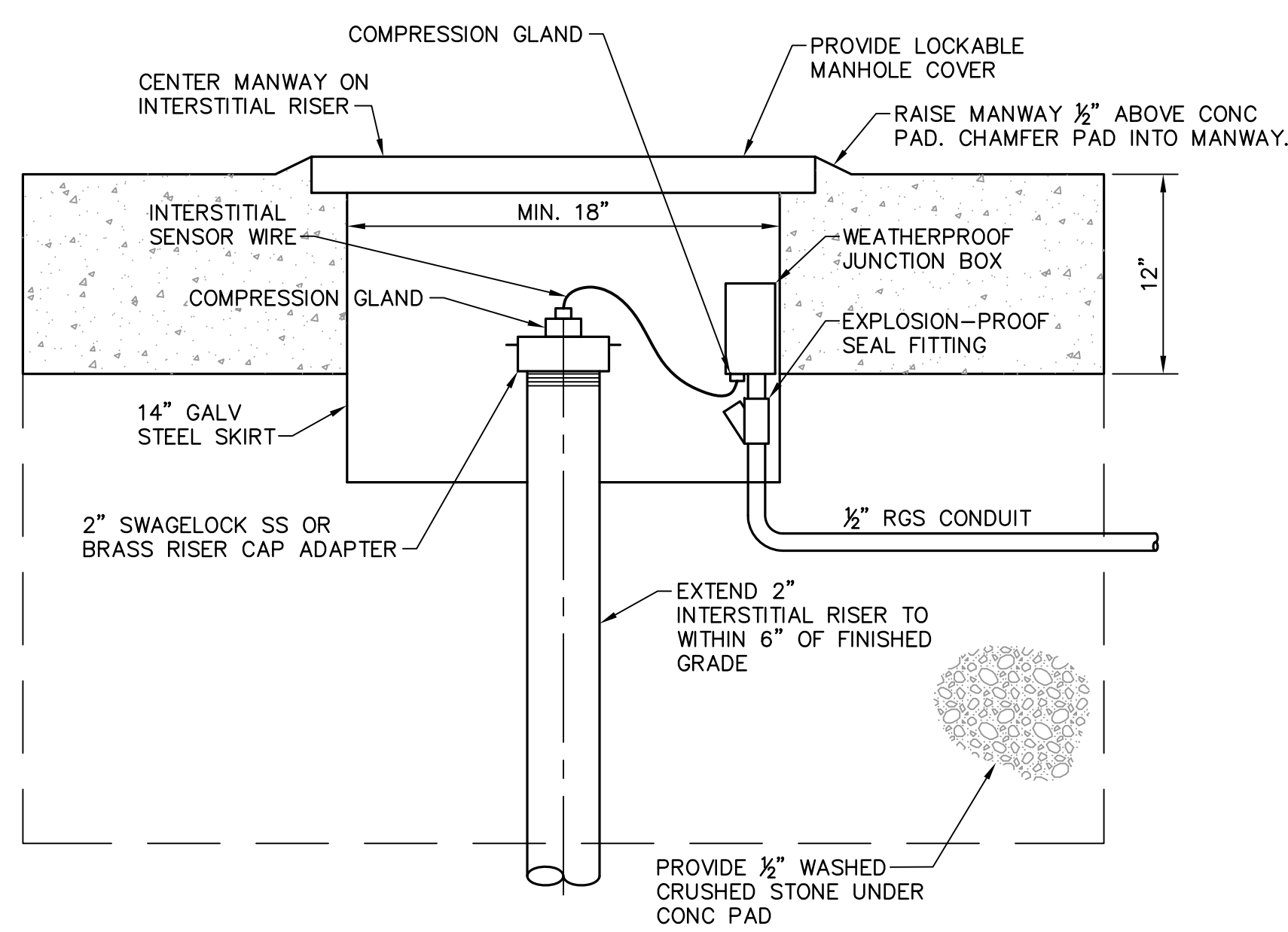

TYPICAL INTERSTITIAL MONITORING ACCESS MANHOLE
NO SCALE

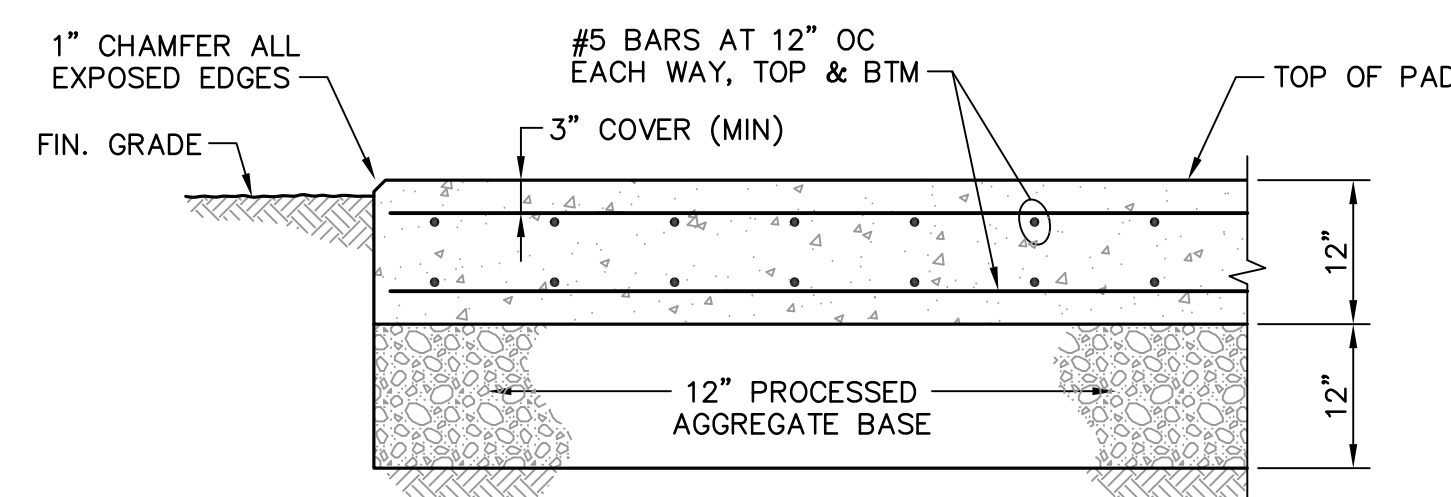

NOTES:
1. CONCRETE SHALL BE 5000 PSI CONCRETE WITH 3/4" AGGREGATE.

CONCRETE PAD
NO SCALE

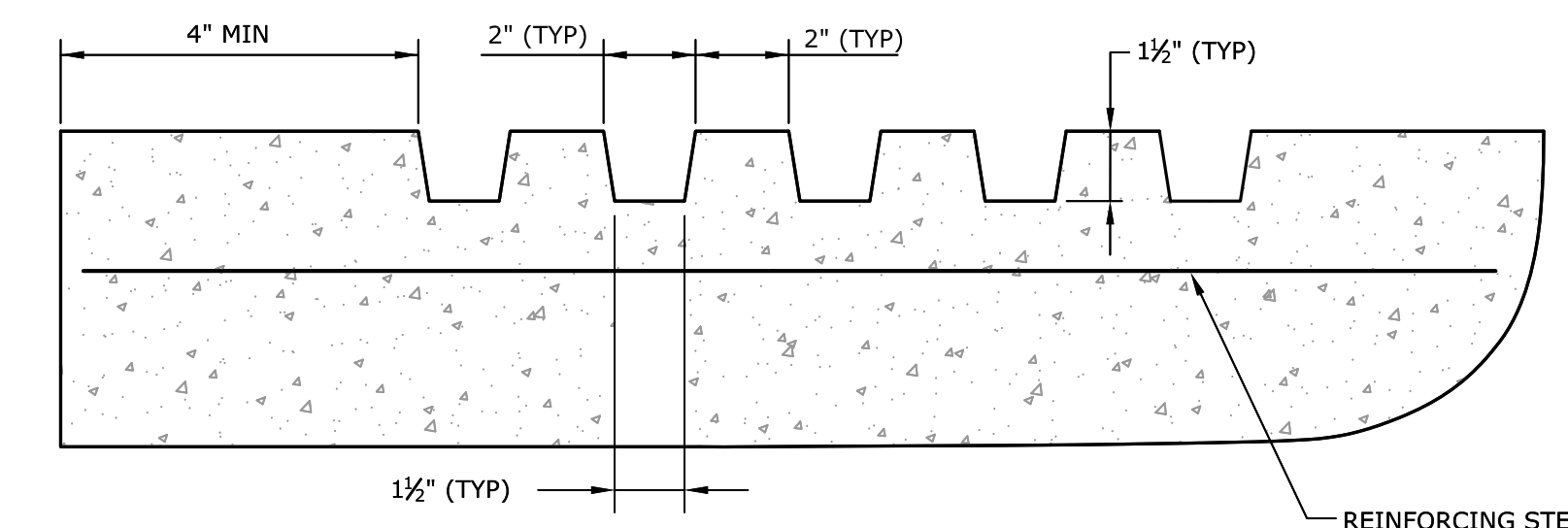

POSITIVE LIMIT BARRIER
NO SCALE

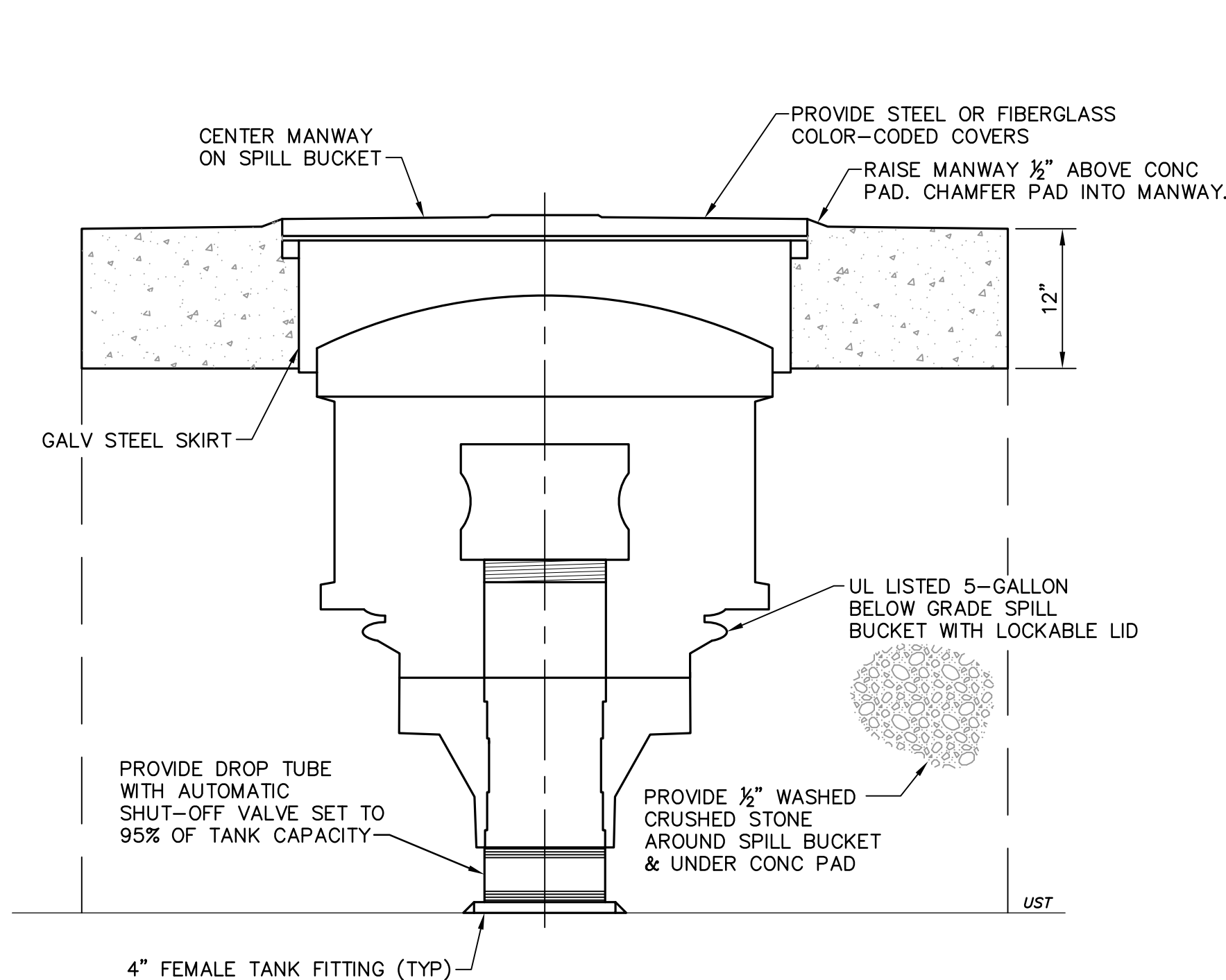

NOTES:
1. TANK FILL DROP TUBES SHALL EXTEND TO WITHIN 4 INCHES OF THE TANK BOTTOM.

TYPICAL 5-GALLON BELOW GRADE SPILL BUCKET
NO SCALE

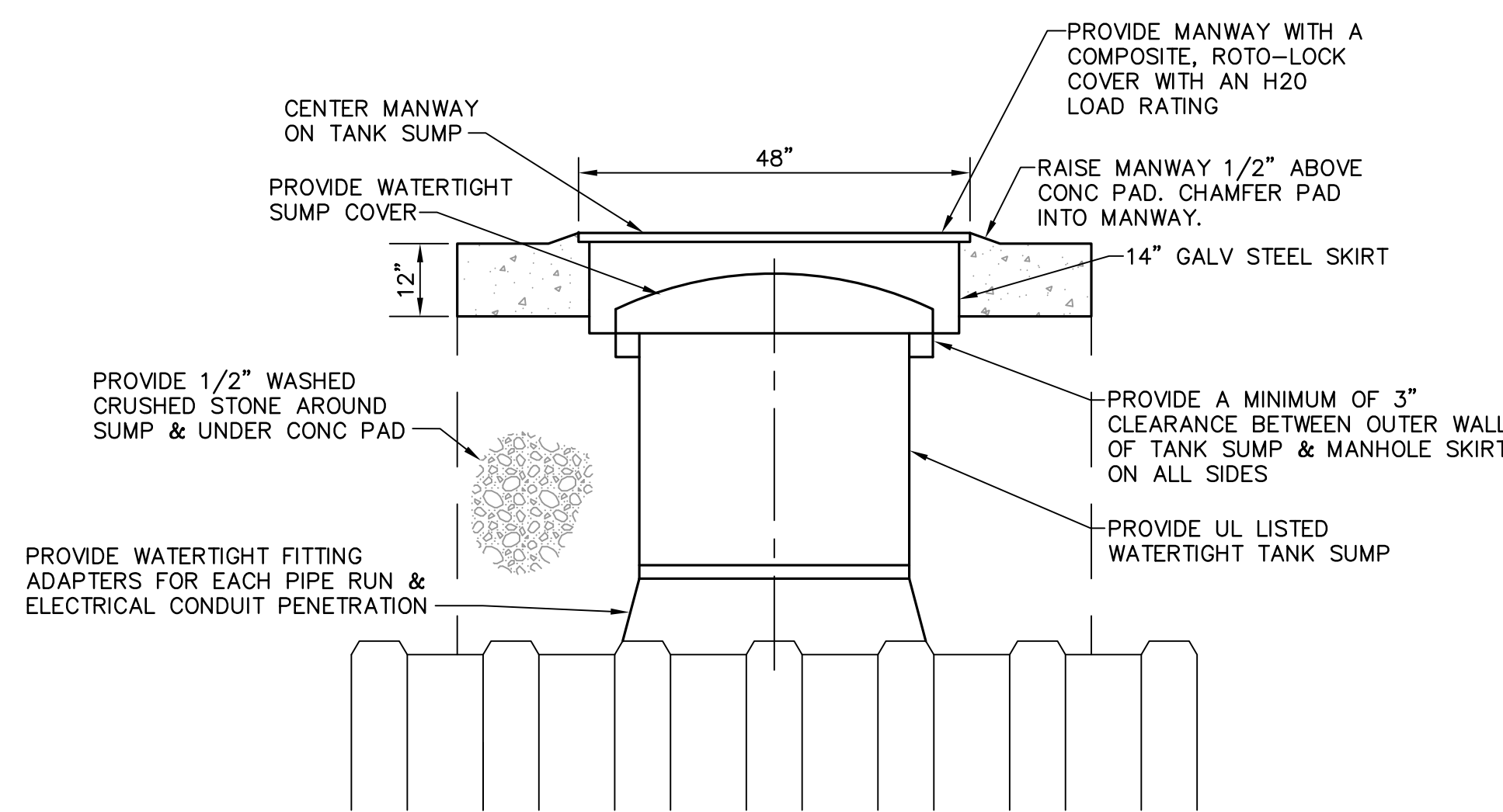

NOTES:
1. TANK SUMPS AND SUMP PENETRATION ENTRY BOOTS AND ADAPTERS SHALL BE INSTALLED BY A CONTRACTOR THAT IS CERTIFIED BY THE MANUFACTURER.
2. ALL SUMPS AND SPILL BUCKETS SHALL BE HYDROSTATICALLY TESTED PRIOR TO INTRODUCING FUEL INTO ANY PORTION OF THE TANK'S PIPING.
3. HYDROSTATIC TESTING WATER SHALL BE INSPECTED FOR THE PRESENCE OF PETROLEUM FOLLOWING THE TEST. WATERS CAN BE DISCHARGED ON SITE IF NO OIL IS PRESENT.

TYPICAL BELOW GRADE TANK SUMP
NO SCALE

NOTES:
1. PROVIDE WASHED 1/2" CRUSHED STONE BACKFILL, NATIVE SOILS ARE NOT PERMITTED FOR TANK EXCAVATION.
2. CONTRACTOR SHALL CONDUCT AN AIR TEST ON EACH TANK BEFORE INSTALLATION AND AFTER ALL EQUIPMENT IS INSTALLED, BUT BEFORE FILLING. TEST SHALL BE CONDUCTED IN ACCORDANCE WITH THE MANUFACTURER'S SPECIFIED PROCEDURES. PRESSURES SHALL NOT EXCEED 5 PSI.
3. PROVIDE A MINIMUM OF 24" OF NEW COMPACTED BACKFILL ON ALL SIDES AND BOTTOM OF TANKS.
4. ANCHOR STRAPS MUST BE LOCATED AT THE MANUFACTURER'S DESIGNATED LOCATIONS. A MINIMUM OF TWO ANCHOR POINTS ARE REQUIRED PER TANK. ANCHOR POINTS ARE SHOWN IN THE TANK DETAIL DRAWING.
5. EACH ANCHOR STRAP SHALL HAVE AT LEAST ONE TURN BUCKLE.
6. DEADMEN ARE TO BE LOCATED OUTSIDE THE FOOTPRINT OF THE TANKS.
7. ANCHOR STRAPS AND TURNBUCKLES MUST MEET THE MANUFACTURER'S REQUIREMENTS.
8. BACKFILL SHALL BE PLACED IN EVENLY DISTRIBUTED 12" LIFTS. BACKFILL MATERIAL SHALL BE WORKED TO FILL ALL VOIDS.
9. CONTRACTOR SHALL PROVIDE A COMPLETED "TANK INSTALLATION LIST" UPON COMPLETION OF THE PROJECT.
10. ALL MANWAYS, HANHOLES AND SPILL BUCKETS ARE TO BE RAISED/CHAMFERED 1/2".
11. TANK AND FUELING AREA ORIENTATION SHALL BE CONFIRMED BY OWNER PRIOR TO TANK INSTALLATION.
12. ALL MANWAYS SHALL HAVE A MINIMUM OF H=20 LOAD RATING.

SECTION 13 20 10

FLEET FUELING STATION

PART 1 GENERAL

1.01 SECTION INCLUDES

- A. Attention is directed to the CONTRACT AND GENERAL CONDITIONS and all Sections within DIVISION 1 - GENERAL REQUIREMENTS, which are hereby made a part of this Section of the Specifications.
- B. General:
 - 1. Fire Suppression System
 - 2. Underground Storage Tank Systems
 - 3. Fuel Monitoring System
 - 4. Fuel Management System

1.02 REFERENCES

- A. Fire Suppression System
 - 1. 527 Code of Massachusetts Regulations (CMR) 1.00, *Massachusetts Comprehensive Fire Safety Code*
 - 2. National Fire Protection Association (NFPA) 17, *Standard for Dry Chemical Extinguishing Systems*, 2009 Edition
 - 3. NFPA 30, *Flammable and Combustible Liquids Code*, 2012 Edition
 - 4. Underwriter's Laboratories (UL) 1254, *Standard for Pre-Engineered Dry Chemical Extinguishing System Units*, 2013 Edition
- B. Underground Storage Tank Systems
 - 1. 527 CMR 1.00, Massachusetts Comprehensive Fire Safety Code
 - 2. 310 CMR 80.00, Underground Storage Tank Systems
 - 3. NFPA 30, Flammable and Combustible Liquids Code, 2012 Edition
 - 4. NFPA 30A, Motor Fuel Dispensing Facilities and Repair Garages, 2012 Edition
 - 5. UL 1316, Glass-Fiber-Reinforced Plastic Underground Storage Tanks for Petroleum Products, Alcohols, and Alcohol-Gasoline Mixtures, 1994 Edition

6. American Petroleum Institute (API) Recommended Practice 1615, Installation of Underground Petroleum Storage Systems, 6th Edition
7. UL 1316, Glass-Fiber Reinforced Plastic Underground Storage Tanks for Petroleum Products, Alcohols, and Alcohol-Gasoline Mixtures
8. Petroleum Equipment Institute (PEI) Recommended Practice (RP) 100, Installation of Underground Liquid Storage Systems, 2012 Edition
9. PEI RP 300, Installation and Testing of Vapor-Recovery Systems at Vehicle Fueling Sites, 2009 Edition

C. Fuel Monitoring System

1. 527 CMR 1.00, Massachusetts Comprehensive Fire Safety Code
2. 310 CMR 80.00, Underground Storage Tank Systems
3. NFPA 30, Flammable and Combustible Liquids Code, 2012 Edition
4. NFPA 30A, Motor Fuel Dispensing Facilities and Repair Garages, 2012 Edition
5. American Petroleum Institute (API) Recommended Practice 1615, Installation of Underground Petroleum Storage Systems, 6th Edition
6. Petroleum Equipment Institute (PEI) Recommended Practice (RP) 100, Installation of Underground Liquid Storage Systems, 2012 Edition

D. Fuel Management System

1. 527 CMR 1.00, Massachusetts Comprehensive Fire Safety Code
2. 310 CMR 80.00, Underground Storage Tank Systems
3. NFPA 30, Flammable and Combustible Liquids Code, 2012 Edition
4. NFPA 30A, Motor Fuel Dispensing Facilities and Repair Garages, 2012 Edition
5. American Petroleum Institute (API) Recommended Practice 1615, Installation of Underground Petroleum Storage Systems, 6th Edition
6. Petroleum Equipment Institute (PEI) Recommended Practice (RP) 100, Installation of Underground Liquid Storage Systems, 2012 Edition

1.03 QUALITY ASSURANCE

- A. All equipment provided for the project must be new and installed in a workman like manner in accordance with the manufacturer's requirements.
- B. Fire Suppression System

1. The design and layout of the fire suppression system shall be approved and stamped by a licensed Massachusetts Fire Protection Engineer.
 2. UL-Listed Products - Provide only new components, which are UL-listed and bear UL "Listing Mark" for type, rating, and classification indicated.
 3. Equipment manufacturers shall have a minimum of ten years of experience in the design and manufacture of equipment of similar size, type, and capacity.
 4. Contractor shall verify tank integrity at the time of delivery from the manufacturer and the integrity of the tank and piping system upon completion of the installation.
 5. The completed system shall be tested in accordance with the requirements of UL 1254.
- C. Underground Storage Tank Systems
1. Manufacturer shall have a minimum ten years' experience in the design and manufacture of equipment of similar size, type, and capability.
 2. 100% of the primary and secondary containment for the tank and piping shall be tested for tightness following an approved testing method.
- D. Fuel Monitoring System
1. Manufacturer shall have a minimum ten years' experience in the design and manufacture of equipment of similar size, type, and capability.
 2. 100% of the primary and secondary containment for the tank and piping shall be tested for tightness following an approved testing method.
- E. Fuel Management System
1. Manufacturer shall have a minimum ten years' experience in the design and manufacture of equipment of similar size, type, and capability.
 2. 100% of the primary and secondary containment for the tank and piping shall be tested for tightness following an approved testing method.

1.04 SUBMITTALS

- A. Refer to SECTION 01 33 00 - SUBMITTALS for submittal provisions and procedures.
- B. Fuel Suppression System
 1. Shop drawings and manufacturer's product information for each piece of equipment included in this Section.

2. Drawing(s), bearing the seal of a licensed Massachusetts Fire Protection Engineer showing:
 - a. The proposed layout and distribution area of the fire suppression system
 - b. Total number of nozzles and orientation of the nozzle clusters
 - c. Location and total number of cylinders
 - d. Location(s) of thermal sensors
 3. Warranty information
 - a. Provide a two-year warranty for fire extinguishing system components. Warranty shall start at the date of substantial completion.
- C. Underground Storage Tank Systems
1. Submit manufacturer's data sheets on each product to be used.
 2. Submit product certificates signed by the manufacturer certifying material compliance with specification.
 3. Submit warranty information.
- D. Fuel Monitoring Systems
1. Submit manufacturer's data sheets on each product to be used.
 2. Submit product certificates signed by the manufacturer certifying material compliance with speciation.
 3. Submit warranty information.
- E. Fuel Management System
1. Manufacturer shall have a minimum ten years' experience in the design and manufacture of equipment of similar size, type, and capability.
 2. 100% of the primary and secondary containment for the tank and piping shall tested for tightness following an approved testing method.

PART 2 PRODUCTS

2.01 FIRE SUPPRESSION SYSTEM

A. General

1. Provide a pre-engineered fire suppression system for protection of the fleet fueling station vehicle fueling area manufactured by Pyro-Chem, Kiddie, or approved equal.

7. A union shall be installed in the discharge piping conveniently close to the cylinder valve to permit disconnection for inspection and service.

F. Portable Fire Extinguishers

1. Provide one 20-pound, type B:C portable fire extinguisher, sign, mounting hardware and soft cover.
2. The portable fire extinguisher shall be mounted on one of the canopy columns.
 - a. The fire extinguisher handle shall be 3” above surface grade.
 - b. The fire extinguisher sign shall be located on the column, directly above the fire extinguisher, at a height of 6’, measure from the island surface to the bottom of the sign.

2.02 UNDERGROUND STORAGE TANK SYSTEMS

A. General

1. Provide two (2)6,000-gallon brine filled Glass-Fiber-Reinforced Plastic (FRP) UST systems to include dead men, hold down straps, backfill and appurtenances detailed in this Section.
 - a. Provide suitable backfill material for the tank excavation in accordance with the manufacturer’s installation instructions.
 - i. Excavated native soil and fill material shall not be reused as backfill or fill over the top of the tanks.
 - ii. Acceptable backfill material shall be clean ¾” pea stone or ½” crushed stone.
 - iii. Backfill shall be placed in 12” lifts, each lift shall be properly worked so as to eliminate voids in the bedding material around the tanks.
2. Provide two (2) non-metallic, fiberglass tie down straps for each tank, straps shall be manufactured by the tank manufacturer for the purpose of anchoring the UST.
 - a. A minimum of one turnbuckle shall be provided for each strap.
 - b. Each strap attachment shall be made to separate anchor points.
 - c. Straps shall have a minimum width of 2”.
 - d. Anchor straps shall be uniformly tightened using the turnbuckles or come-a-longs.
 - e. Contractor shall record deflection measurements for each tank following the instruction and intervals as determined by the manufacturer.

- i. A copy of the deflection measurements shall be provided to the Prime Designer with the tank installation checklist.

B. Leak detection sumps

1. Provide and install one 42" FRP tank top sump on each UST.
 - a. Sumps shall be fitted to the tank collar following the manufacturer's instructions.
 - b. Both sumps shall be hydrostatically tested in accordance with the manufacturer's instructions and the requirements of 310 CMR 80.00 before filling the tanks.
2. Provide and install two dispenser sumps, one beneath each dispenser.
 - a. Sumps shall be compatible with gasoline and diesel.
3. Provide 48" steel manhole rings and covers as shown on the Drawings.
4. The steel manhole ring and tank top leak detection sump and cover and concrete pad shall be of design and construction to meet an H-20 load rating. The steel ring frame shall have a galvanized steel skirt of at least 14" in depth and of at least 14-gauge steel construction. The manhole ring, cover and concrete pad shall be of size and design to be compatible with the manhole/sump riser system.
5. Manhole ring and covers shall be set 1/2" above finished grade. The concrete pad shall be sloped around the manhole perimeter to direct water away from the manhole.
6. Sump testing:
 - a. Contractor shall conduct a hydrostatic test of the tank top piping leak detection sumps and the under dispenser leak detection sumps by filling the sump to the top with water.
 - b. The test will be considered a failure if there is a loss of 1/8" or more of water over a period of one hour.
 - c. Should one or both sumps fail the hydrostatic test, the contractor shall be responsible for repairing or replacing the sump(s) that failed the test at no cost to the Owner.
 - d. In the event of a hydrostatic test failure, Contractor shall conduct additional hydrostatic testing until the sump meets the criteria listed in 4.4.2.A.3, above.
 - e. Provide records of the hydrostatic test to the Owner and Prime Designer. The records shall include the results of the test, date and time of the test and the name and company of the individual performing the test.

C. Double wall pipe

1. Provide and install 2"FRP double wall pipe for gasoline and diesel service to two (2) twin-hose, dual product fuel dispensers.
 - a. Each fuel dispenser shall have one gasoline service pipe and one diesel service pipe.
 - b. Piping shall be compatible with the material stored.
 - c. Piping shall be constructed with a primary pipe and secondary pipe capable of containing release from the primary pipe for the purpose of leak detection.
 - d. Provide and install one testable emergency shut-off shear valve with a fusible link below each dispenser, OPW 10 series or approved equal.
 - i. The emergency shut-off shear valve shall be fastened to a stabilizer bar mounted to the concrete fuel island.
 - ii. Emergency shut-off valve shall be rigidly anchored with the shear section even with the top surface of the pump island.
2. Sump entry boots shall be provided at each pipe and conduit penetration through a sump wall.
 - a. Entry boots shall be bonded to the sump wall in accordance with the manufacturer's installation instructions.
 - b. All sump penetrations shall be watertight.
 - c. Pipe and conduit penetrations shall exit through the sump wall at an angle perpendicular to the sump wall.
 - d. The angle of pipe and conduit penetrations shall not exceed 10 degrees off the centerline of the entry boot flange.

D. Fuel Dispensers

1. Contractor shall provide one (1) twin hose fleet fueling suction pump dispenser with internal filters, Wayne Select EC Series, or approved equal.
 - a. Product identification panels shall be illuminated.
 - b. Pump cabinet shall be constructed of 304 stainless steel.
 - c. The dispenser shall have one gasoline and one diesel nozzle.
 - d. Dispenser cabinet and nozzles shall be side loading type.
 - e. Provide standard UL listed diesel hoses for diesel and gasoline.
 - i. Hoses shall be a minimum of 16' in length and 3/4" in diameter.

- ii. Gasoline and diesel hoses shall have UL657 listed dry breakaway connections.
 - iii. Nozzles shall be color coded to the fuel with multiplane swivels.
 - iv. Diesel nozzles shall be
 - f. Dispenser shall have a pulse output interface for gasoline and diesel.
 - g. Provide counterweight type hose retractor for gasoline and diesel hoses that is capable of holding the entire hose off the ground/concrete pad.
 - 2. Dispenser pumps shall be a positive displacement pump.
 - a. Pumps shall be self-priming with an integral air separator an adjustable bypass valve and inlet strainers.
 - b. Pumps shall be capable of providing a 22 gallon per minute flow rate.
 - 3. Electrical requirements
 - a. Motor shall be a 1-HP continuous duty with thermal overload protection.
 - b. 240VAC, 60 Hz.
 - 4. Dispenser display shall be a backlit LCD display showing a minimum of six digits.
 - a. Display shall remain lit for a minimum of 15-minutes in the event of a power failure.
 - 5. Dispenser shall be compatible with the following fuel blends:
 - a. B20
 - b. E15
- E. Overfill Prevention
- 1. Provide and install one OPW 61SO overfill prevention valve in each UST, or approved equal.
 - a. Automatic shut off valves shall be set to limit the tank volume to 95% capacity.
 - b. Valves shall be compatible with the material stored.
 - c. Drop tube shall extend to within 4" of the tank bottom.
 - 2. Provide quick connect style adaptors with vapor tight caps for the tank fill connection.
 - a. The gasoline tank shall be equipped with a compliant Stage 1 Enhanced Vapor Recovery (EVR) vapor tight swivel adaptor.

F. Emergency Electrical Disconnect

1. Provide and install one emergency electrical disconnect switch on the exterior of the building.
 - a. Emergency electrical disconnect switch shall disconnect all power to all dispensing devices, remote pumps, fuel management system, fuel monitoring system, canopy lights and all other electrical equipment located within the fueling area.
 - b. Emergency electrical disconnect switch shall be clearly identified with a sign using 1" white letters on a red background as follows:

“EMERGENCY SHUT-OFF SWITCH”

G. Fuel Island

1. Island forms shall be 9¼" tall stainless steel forms manufactured by Burtco, or approved equal.
2. U-shaped pipe bollards shall be constructed of 4" diameter stainless steel, manufactured by Burtco, or approved equal.

2.03 FUEL MONITORING SYSTEM

A. General

1. Provide and install one new, complete UST fuel monitoring system, conduit and electrical wiring.
 - a. Provide two new tank level probe for monitoring both fuel and water level sensing in the fuel storage tanks.
 - b. Metallic probe components shall be of stainless steel construction.
 - c. Floats shall be compatible with the material stored.
 - d. Tank level probes shall be calibrated to provide an overfill alarm at 90% capacity.
 - e. Provide 2 new sump leak detection sensors for the piping and dispenser sumps.
 - f. One sensor shall be installed in each tank piping sump.
 - g. One sensor shall be installed in each dispenser sump.
 - h. Fuel monitoring system shall be programmed to perform inventory reconciliation.
 - i. Provide one new alarm console and acknowledgement switch.

- j. Confirm placement of alarm and acknowledgement switch with Owner and Engineer prior to installation.

2.04 FUEL MANAGEMENT SYSTEM

A. General

1. Provide one OPW K800Hybrid Fuel Control System, no approved equal.
 - a. Fuel island terminal shall be equipped with an emergency electrical disconnect switch.
 - i. A second emergency electrical disconnect switch will be installed, see project Drawings.
 - b. The fuel island terminal enclosure shall be weatherproof with a LED backlit display.
 - c. Keypad shall be constructed of UV-stable weather-resistant material; contacts shall be stainless steel.
 - d. Provide 120/240 VAC electrical service to the Fuel Island Terminal as show on the Drawings.
 - e. The equipment shall have an operating range of -40 degrees Fahrenheit to 122 degrees Fahrenheit.
1. Provide 150 chip keys, Prime Designer will determine if magnetic stripe cards or chip keys will be required.
 - ii. The system shall also be compatible with magnetic-strip cards.
2. Provide one FSC3000 Fuel Site Controller, to be located in the in the office building onsite.
 - a. Confirm location of FCS300 Fuel Site Controller with the Owner and Prime Designer before installing the equipment, conduit or wiring.
 - b. Provide Phoenix Premier software.
 - i. Software shall be configured to perform reconciliation with the Fuel Tank Gauging system.
 - ii. Software shall provide remote monitoring of project and pump totals on demand.
 - iii. Provide expanded memory package to accommodate a minimum of 64,000 cards and 2,000 transactions.

PART 3 EXECUTION

3.0.1 GENERAL

- A. CONTRACTOR, prior to installation, shall obtain the required tank installation permits. Permitting costs shall be paid by the contractor.
- B. Furnish all labor, materials, equipment and supervisory, operating and monitoring personnel to conduct the Work as shown on the plans and specified herein in a safe and professional manner.
- C. Installation of equipment and materials shall be in accordance with the manufacturer's recommended practice and appropriate sections of the Project Manual. Where conflict occurs between regulatory requirements, the manufacturer's recommendation and the Project Manual or plans, the more stringent will take precedence.

END OF SECTION